

THE COMPANY	Pag. 2
ETEREA	Pag. 14
CONTEMPORA	Pag. 64
CLASS	Pag. 118
REI	Pag. 162
ALISEA	Pag. 170
APERTURE SPECIALI	Pag. 218





the company

i numeri del nostro successo

La Pail è un'azienda leader nel settore della produzione di porte interne e serramenti in legno, legno-alluminio, alluminio e PVC. Una realtà produttiva che conta oltre 250 dipendenti, suddivisi in quattro stabilimenti che coprono una superficie complessiva di circa 100mila mq (di cui 45mila mq coperti).

Produce annualmente 90mila porte interne, 30mila serramenti esterni, semilavorati e componenti in legno, destinati sia al mercato nazionale che a quello estero.

La PAIL garantisce tempi di consegna ineguagliabili: 30 giorni per le porte, 60 giorni per i serramenti.

the numbers of our success

Pail is a leading company in producing internal doors and wooden, wooden-aluminium, aluminium and PVC windows. One productive world that has more than 250 subordinates shared on four factories, on about 100.000 mq surface (45.000 mq covered surface).

Every year Pail makes out 90.000 internal doors, 30.000 external windows, semi-manufactured and wooden components, for home and foreign market. Pail guarantees matchless delivery terms: 30 days when it's about doors and 60 days when it's about external doors.



the family

Amministratore Unico e Legale Rappresentante:
Amerigo Pellegrini

Responsabile Produzione-Acquisti
Sandro Pellegrini

Responsabile Tecnico
Fausto Pellegrini

Responsabile Amministrativo-Finanziario
Paolo Pellegrini

Responsabile Commerciale
Emanuela Pellegrini



50 anni di storia

La nostra storia è quella di una piccola realtà artigianale iniziata 50 anni fa quando Amerigo Pellegrini, giovane falegname, fondò un laboratorio di soli 100 mq per la produzione di porte e finestre in legno. Oggi Amerigo Pellegrini è il presidente della Pail Serramenti, un'azienda che ha saputo evolversi in chiave industriale grazie alla profonda conoscenza del legno, al rispetto di antiche tecniche di lavorazione e alla costante ricerca per l'innovazione tecnologica. Sandro, Fausto, Paolo e Emanuela Pellegrini affiancano oggi il padre nella gestione di questa grande Azienda.

50 years history

This is a story about a small world, that began 50 years ago when Amerigo Pellegrini, young carpenter, started a craftmade lab on just 100 mq, in order to produce wooden doors and windows. Nowadays Amerigo Pellegrini is the President of the Pail Serramenti, a company that has been able to evolve in an industrial way, thanks to a deep knowledge of wood, thanks to respect for old work-techniques and steady research to technological innovation. Sandro, Fausto, Paolo and Emanuela Pellegrini stay by their father, managing this big Company.

1963

Inizio dell'attività di falegnameria
Start of carpentry

1972

Primo stabilimento industriale PAIL 1 (750 mq)
First industrial factory PAIL 1 (750 mq)

1975

Sviluppo mercato interregionale e prime commesse estere
Shop for the interregional market and the first foreign contracts

1985

Ampliamento stabilimento PAIL 1 a 6.000 mq
Factory expansion to PAIL 1 6.000 mq

1994

Apertura stabilimento PAIL 4 (10.000 mq)
Open factory PAIL 4 (10.000 mq)

1998

Apertura stabilimento PAIL 2 (18.000 mq)
Open PAIL 2 factory (18.000 mq)

2003

Apertura stabilimento PAIL 3 (10.000 mq)
Open PAIL 3 factory (10.000 mq)

2009

Avvio Divisione Serramenti PVC e Nuovi Uffici
PVC Windows Division and New Offices



materials

dalla nobiltà del legno alla tecnologia avanzata del PVC

La piena soddisfazione dei nostri clienti ci ha spinto ad offrire prodotti di alta qualità e fortemente diversificati. All'originaria materia prima legnosa, selezionata e controllata severamente all'origine, si sono affiancati nel tempo l'alluminio e il PVC, con i quali vengono realizzati porte interne, serramenti e sistemi oscuranti. Inoltre, una divisione interna PAIL, altamente specializzata, utilizza le medesime materie prime e tecnologie nella produzione di semilavorati e componenti (telai, cornici, bugne etc.), a garanzia di uniformità estetica, cromatica e qualitativa.

from nobility wood to high technology PVC

Satisfying our customers pushed us to give high quality items and very different ones. Next to the raw material wood, selected and strictly controlled from the very beginning, PAIL introduced aluminium and PVC too, producing internal doors and windows. Semi-manufactured and wooden components (frame, architraves etc.) made by an internal specialized division Pail, with the same materials and technologies, so that PAIL can guarantee both aesthetic and chromatic evenness.

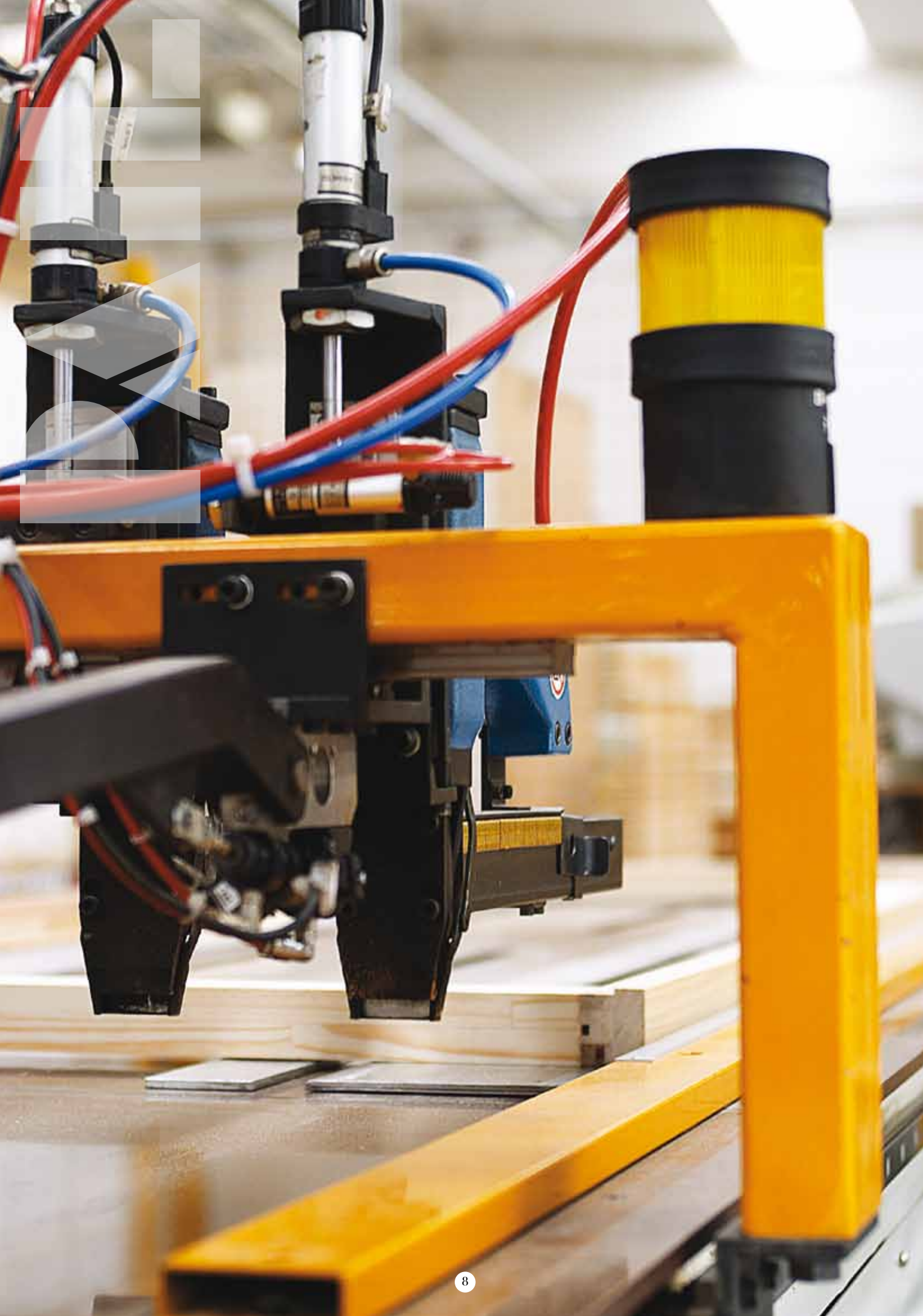

technology

elevata flessibilità produttiva

L'utilizzo di sofisticati impianti computerizzati e macchine a controllo numerico consente agli uomini PAIL di realizzare prodotti personalizzati e su misura, coniugando gli elevati standard qualitativi della produzione industriale con la flessibilità tipicamente artigianale.

high working flexibility

PAIL produces high customized items by advanced technology controlled machines combining the industrial production quality standard with the craftsmanship flexibility.

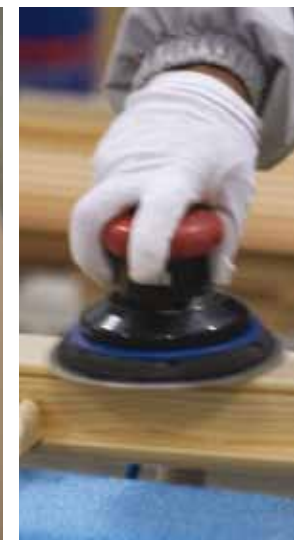

hand care

sintesi di artigianalità e tecnologia

La Pail è una sintesi di artigianalità e tecnologia, proiettata verso l'innovazione e tesa al rinnovamento continuo. Il nostro lavoro si basa sulla competenza dei nostri uomini, che hanno saputo evolversi nel rispetto della tradizione e della cura di ogni singolo prodotto. Sin dall'origine al semilavorato viene assegnato un codice a barre che ne identifica le caratteristiche tecniche e ne consente il controllo e monitoraggio durante tutta la produzione.

mixes craft and technology

Pail mixes craft and technology, it aims at innovation and steady renewal. Our work starts from our men's skills, that have been able to evolve respecting tradition and care for every single item. Since the request, draw materials are given a bar-code that shows the technical characteristics.



Pail point

le nostre esposizioni

Nei nostri showroom, eleganti e confidenziali, apprezzerete l'ampiezza della gamma di porte e serramenti firmata da PAIL; personale qualificato vi consiglierà nella scelta dei modelli che meglio si adattano alle caratteristiche dei vostri ambienti.

our exhibitions

In our showrooms, elegant and confidential, you can find all the products signed by PAIL; qualified staff give you advices in order to the choose of items for yours interiors.

certificazioni _ certifications





Collezione **ETEREA**

*moderna nella concezione,
preziosa nell'estetica,
immutabile nel tempo.*

*modern in concept,
precious look and timeless.*

L'AVETE MAI VISTA?
HAVE YOU EVER SEEN IT?





Elementi decorativi ed accessori esclusivi alternati con sobrietà ed eleganza senza trascurare la praticità. Lo stile di una porta che non rinuncia ad un design lineare e a soluzioni ogni volta singolari.

Valuable elements and exclusive accessories perfectly match with simplicity and elegance without neglecting functional capacity. The style of a door which never gives up a linear design and original solutions.



Illuminazione sotto-porta: un sottile led per un prodotto completo, di forte impatto innovativo. La preziosità di un elemento che, attraverso una discreta luce ambrata, suggerisce atmosfere ricercate.

Side illumination: a thin LED provides the completion of strongly innovative product. The preciousness of the element suggests refined atmospheres through a modest amber-coloured light.



Anta a spingere perfettamente complanare alle cornici sul lato esterno, con totale copertura del telaio. La tecnologia più sofisticata al servizio di una porta che unisce essenzialità e raffinatezza ad una solida funzionalità.

A pushing shutter perfectly coplanar with frames on the outer side and total frame covering. The most sophisticated technology and solid functionality are combined to create a door of exceptional service.



ETEREA®

THE PERFECTION

Scelta ampia e varia delle essenze:

dalle più conosciute a quelle più rare, dalle più classiche a quelle di tendenza. La ricerca di nuovi prodotti e l'attenzione al mercato si traducono in flessibilità dell'offerta per tutti gli stili.

A wide and varied choice of the main features:

from the most famous to rare ones, from the most classic to the most trendy ones. The research of new products and the market focus offers flexibility of styles, for all customers.



PAIL presenta una nuova concezione di porta, espressione della tecnologia e del design di successo: un modello minimale, essenziale nei particolari e singolare nelle soluzioni tecniche adottate.

ETEREA: una porta moderna nella concezione, preziosa nell'estetica, immutabile nel tempo.

PAIL presents a new concept of door, that is characterized by successful technology and design; a model with essential details and original technical solutions.

ETEREA: A door modern in concept, valuable in design and unchangeable in its style.



LA PAIL BREVETTA ETEREA.

Professionalità e serietà premiate da una porta unica per bellezza, eleganza e funzionalità. Un brevetto a garanzia dell'autenticità di un prodotto che esprime la propensione all'innovazione di PAIL, azienda che cresce migliorando l'offerta.

Tutti gli elementi e i componenti grafici, ornamentali e funzionali che compongono il progetto ETEREA sono oggetto delle seguenti domande di brevetto:

- Brevetto per il modello ornamentale n°. PE20070000004
- Brevetto per marchio internazionale n°. 005774329

PAIL PATENTS ETEREA.

Professionalism and reliability take shape in an elegant and steady unique door. A patent guaranteed product which is the expression of the company bent toward change, a company that is growing and improving its offer.

All the elements and graphical, decorative and functional components making up the ETEREA Project are usually the subject of the following patent applications:

- Patent for the decorative model n°. PE20070000004
- Patent for international trademark n°. 005774329



ETEREA®

LUXURY

Il calore del legno, la morbidezza delle finiture, la luce del metallo cromato dell'insero e dei coprifili, si fondono perfettamente con il design moderno degli ambienti interni.

The wood and its finishes, the chrome accessories and the stainless steel architraves covers merge with the modern design of interiors.

LUXURY

Versione: Cieca
Finitura: Wengè
Maniglia: Kit inserto maniglia incluso

Version: shutter door
Finishing: Wengè
Handle: Handle kit included



LUXURY

Versione: Cieca
Finitura: Rovere Bianco Cera
Maniglia: Kit inserto maniglia incluso

Version: shutter door
Finishing: Cera White Tinted Oak
Handle: Handle kit included



LUXURY

Versione: Cieca
Finitura: Rovere
Maniglia: Kit inserto maniglia incluso

Version: shutter door
Finishing: Oak
Handle: Handle kit included



LUXURY

Versione: Cieca
Finitura: Laccato Bianco Lucido
Maniglia: Kit inserto maniglia incluso

Version: shutter door
Finishing: Lacquered White Polished
Handle: Handle kit included





ETEREA®

PREMIUM

Inserto centrale in metallo cromato con maniglia dedicata e nottolino di chiusura fregiato, anta complanare alle cornici esterne, legni selezionati con finiture moderne, cerniere a scomparsa: particolari raffinati e pregiati che fanno della porta ETEREA un complemento d'arredo unico ed originale.

Central metal chrome insert with its typical handle and stylized key, the pushing shutter perfectly flush with the architraves on the outer side and total frame covering, selected woods and chrome vanish hinges; these are refined and valuable details that make ETEREA door an exclusive and original fitting.

PREMIUM

Versione: Cieca
Finitura: Ciliegio
Maniglia: Kit inserto maniglia incluso

Version: shutter door
Finishing: Cherry
Handle: Handle kit included



PREMIUM

Versione: Cieca
Finitura: Wengè
Maniglia: Kit inserto maniglia incluso

Version: shutter door
Finishing: Wengè
Handle: Handle kit included



PREMIUM

Versione: Cieca
Finitura: Laccato Spazzolato Bianco
Maniglia: Kit inserto maniglia incluso

Version: shutter door
Finishing: Brushed white lacquered
Handle: Handle kit included



PREMIUM

Versione: Cieca
Finitura: Laccato Bianco
Maniglia: Kit inserto maniglia incluso

Version: shutter door
Finishing: Lacquered White
Handle: Handle kit included



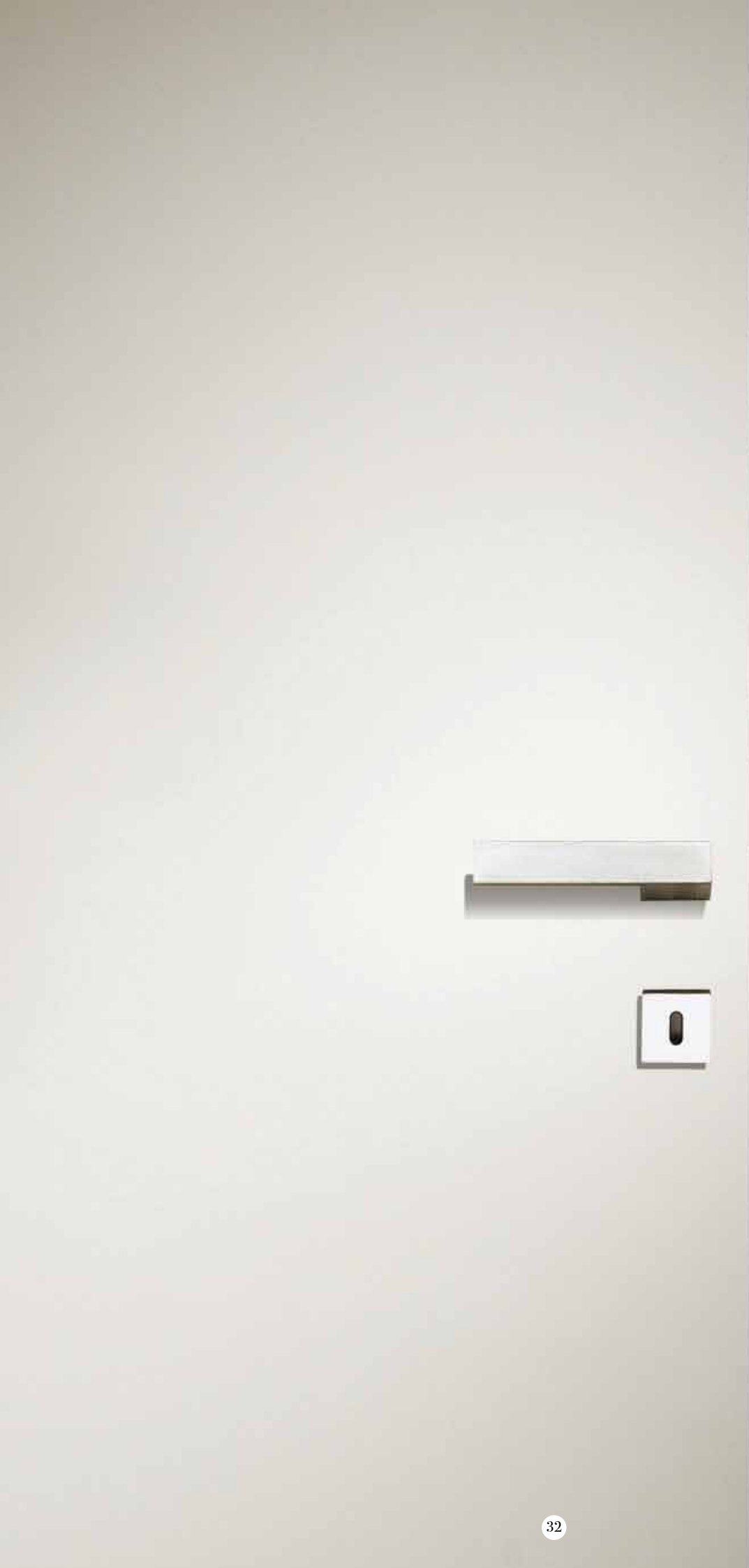

ETEREA®

ELEGANCE

Design moderno e minimale, caratterizzato dal connubio vincente tra il colore e la naturalezza dei legni più pregiati e la luminosità ed essenzialità dell'acciaio inossidabile

This door has a modern and peculiar design characterized by the features of the wood and brilliance of the stainless steel architraves covers.

ELEGANCE

Versione: Cieca
Finitura: Rovere

Version: shutter door
Finishing: Oak



ELEGANCE

Versione: Cieca
Finitura: Rovere Bianco Cera

Version: shutter door
Finishing: Cera White Tinted Oak



ELEGANCE

Versione: Cieca
Finitura: Wengè

Version: shutter door
Finishing: Wengè



ELEGANCE

Versione: Cieca
Finitura: Laccato Bianco Lucido

Version: shutter door
Finishing: Laquered White Polished





ET E R E A[®]

CLASSIC

Linee pulite, essenziali, minimali, di grande effetto per una porta "senza tempo", che sposa con successo ogni scelta d'arredo. Il tutto condito con la cura maniacale dei dettagli e soluzioni tecniche all'avanguardia, come la serratura magnetica e le cerniere a scomparsa registrabili.

This is a traditional door with a harmony of lines that goes well with every kind of furnishings. There are, moreover, painstaking details and cutting-edge technology, like magnetic lock and chrome adjustable vanish hinges.

CLASSIC

Versione: Cieca
Finitura: Laccato Spazzolato Bianco

Version: shutter door
Finishing: Brushed white lacquered



CLASSIC

Versione: Cieca
Finitura: Laccato Bianco

Version: shutter door
Finishing: Lacquered White





ETEREA®

CONVERT

Quando la personalizzazione si spinge oltre ogni livello, nasce ETEREA CONVERT: la libertà di vestire la porta ETEREA con ogni tipo di materiale, dalla morbida pelle naturale, all'eco-pelle, dal tessuto al vetro specchiato.

You can customize ETEREA CONVERT with all kind of materials from natural leather to artificial leather, from fabric to mirror.



CONVERT

Versione: Cieca Rivestimento Tessuto
Finitura:

Version: shutter door
Finishing: Covering Fabric

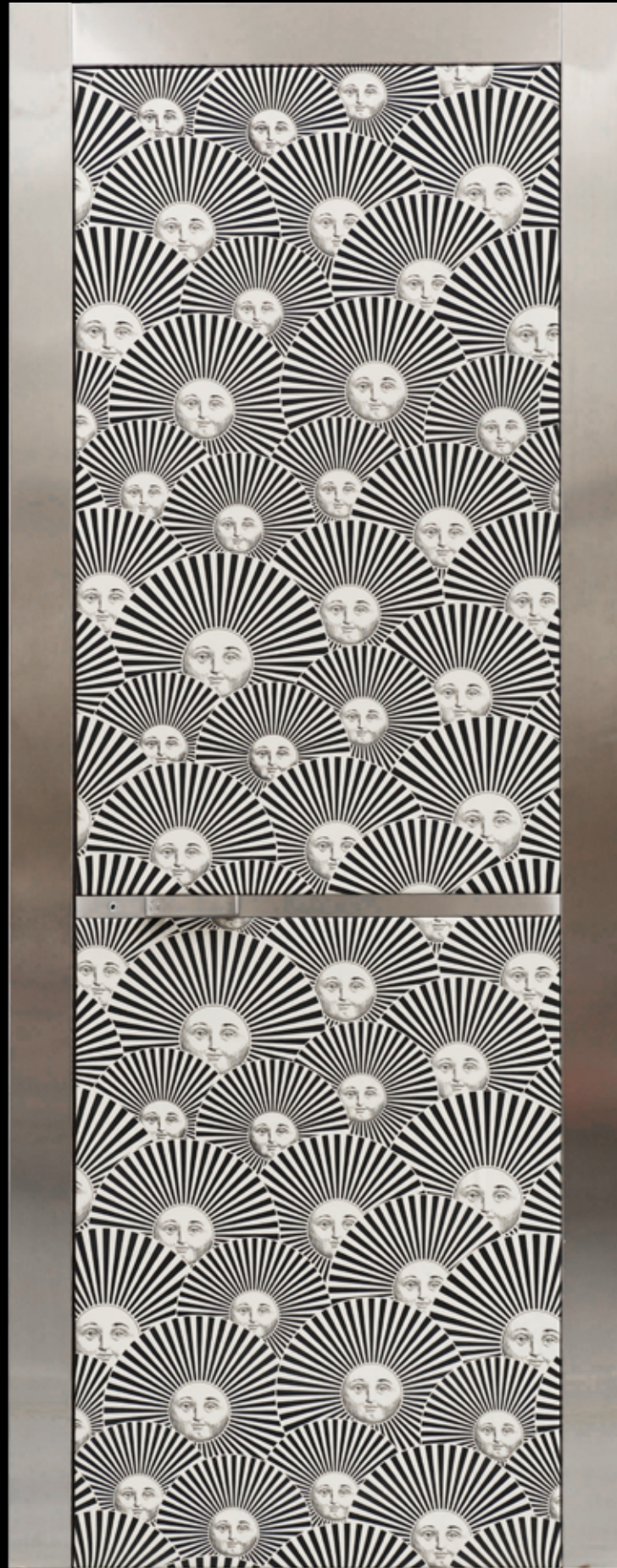

CONVERT

Versione: Cieca
Finitura: Rivestimento Vetro Riflettente

Version: shutter door
Finishing: Covering Reflecting Glass



CONVERT

Versione: Cieca
Finitura: Rivestimento Pelle

Version: shutter door
Finishing: Covering Leather



CONVERT

Versione: Cieca
Finitura: Rivestimento Tessuto

Version: shutter door
Finishing: Covering Fabric

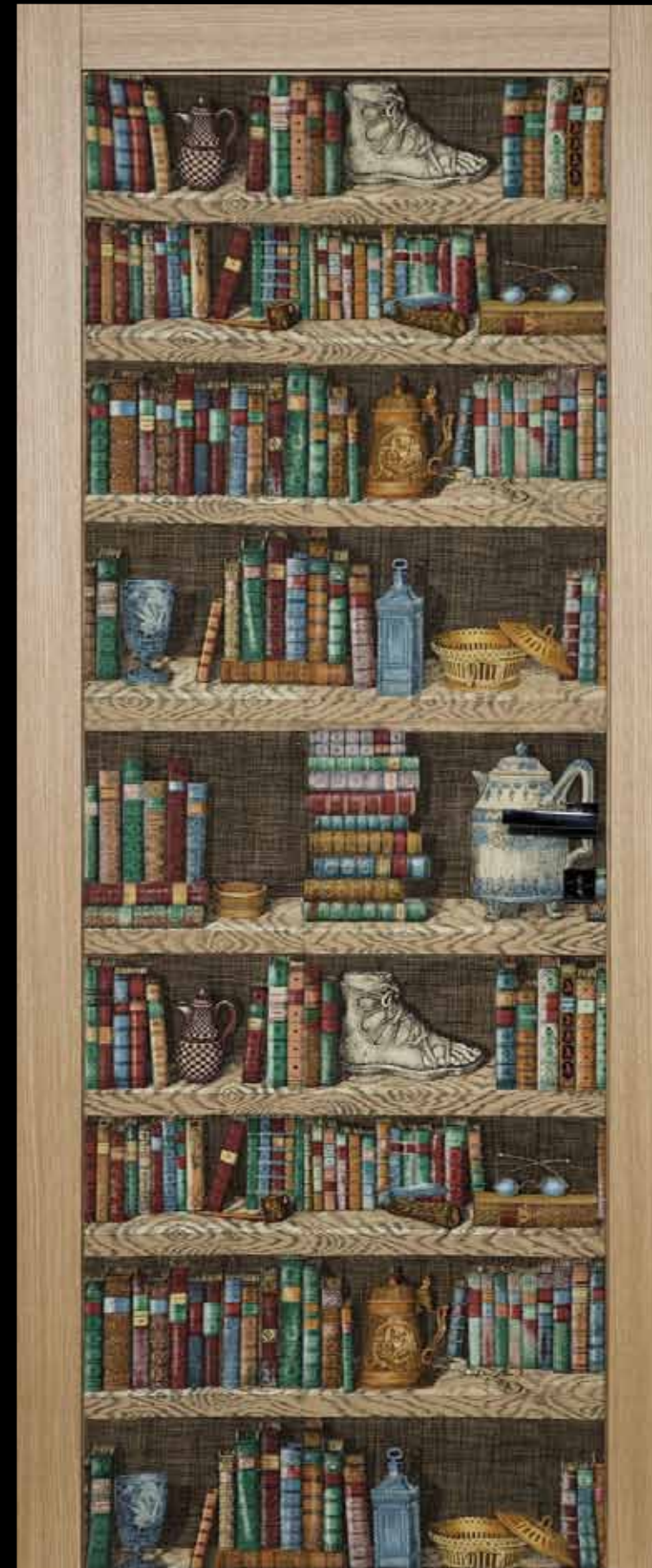

PROSPETTO/FRONT VIEW

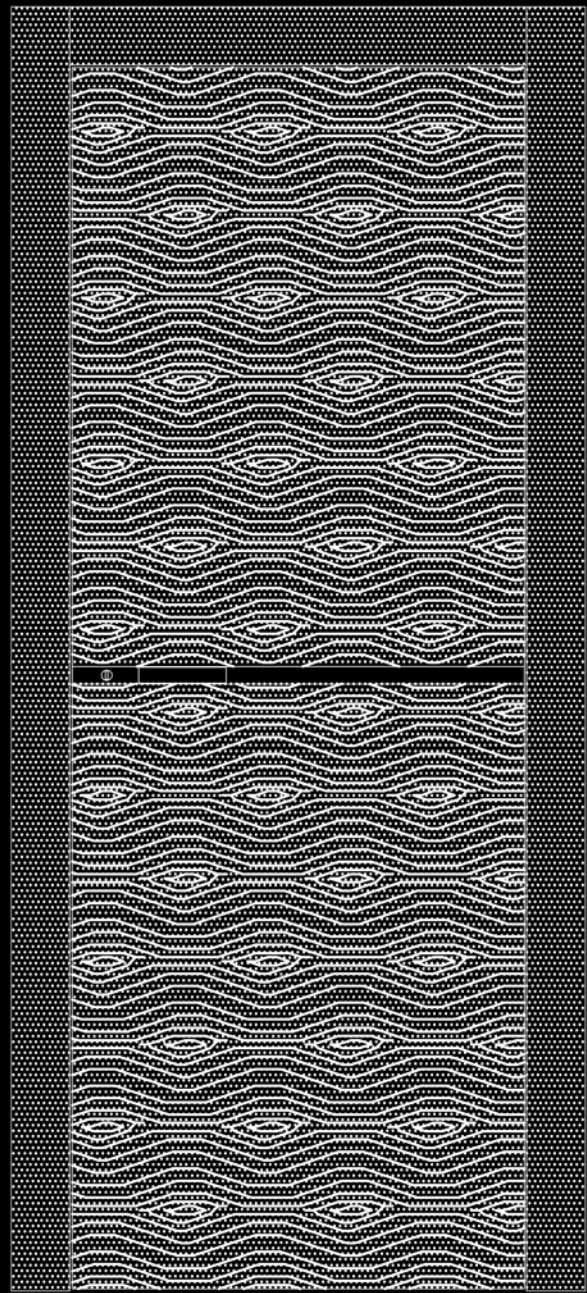

SEZIONE VERTICALE/VERTICAL SECTION

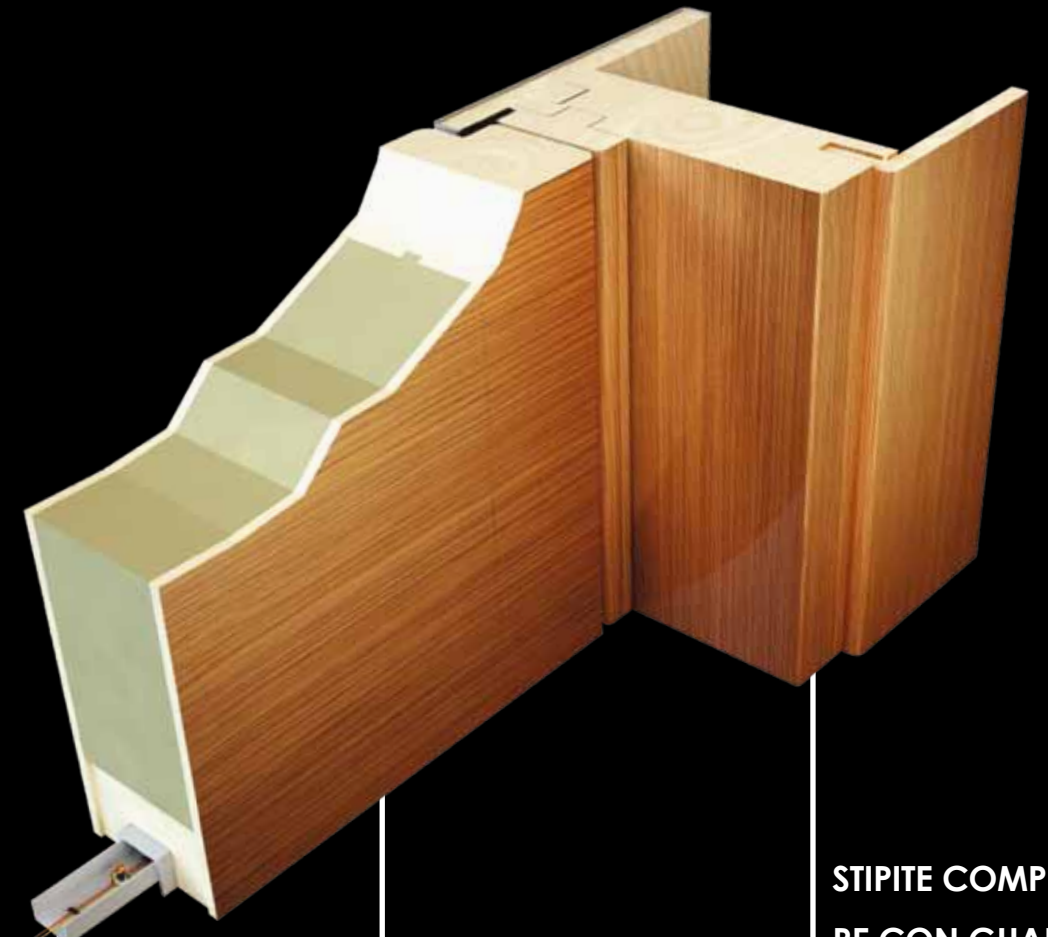
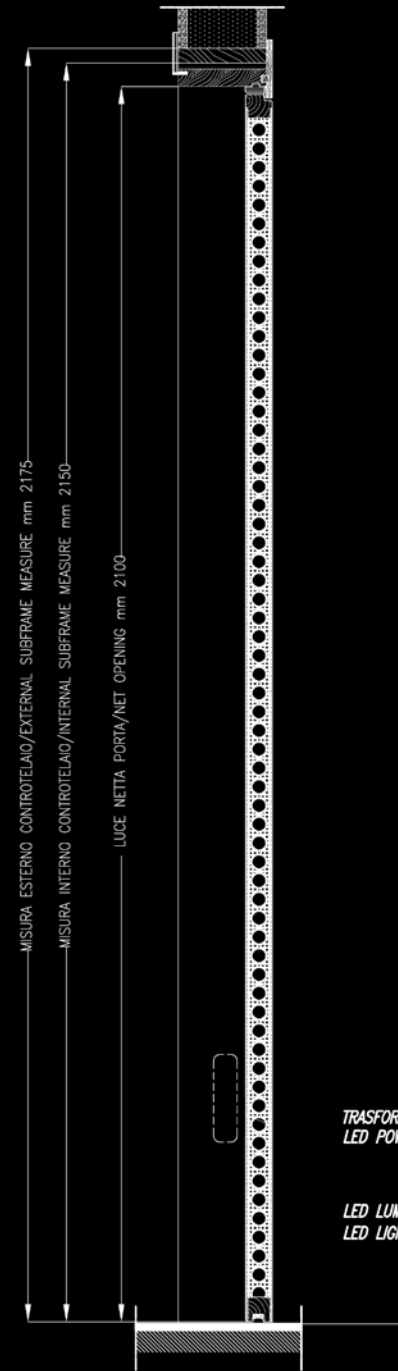

LED LUMINOSO

ANTA COMPLANARE

STIPITE COMPLANARE CON GUARNIZIONE DI BATTUTA

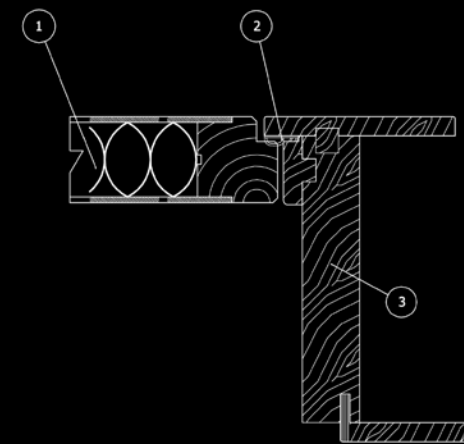

SEZIONE ANGOLO PORTA ETEREA

- 1) Anta complanare
- 2) Guarnizione di battuta
- 3) Stipite complanare

SEZIONE ORIZZONTALE/HORIZONTAL SECTION

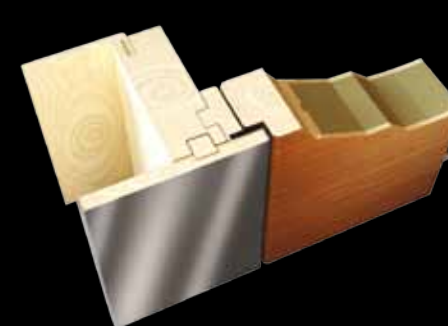
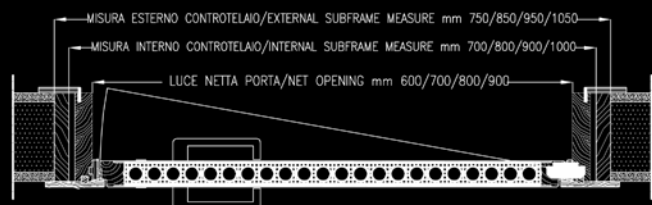

ANTA COMPLANARE



BATTUTA PERIMETRALE

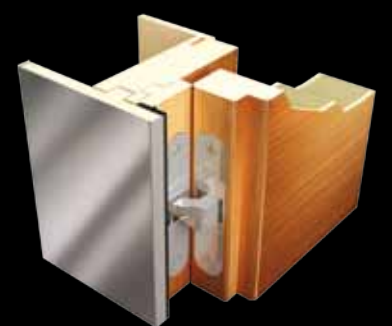

CERNIERA

eterreat

simone micheli

apre una
nuova porta
per **PAIL**



etereat+ code

rivestimento laccato con decoro pantografato
door with lacquered and carved wooden cover



etereea+ game

rivestimento laccato con decoro pantografato
door with lacquered and carved wooden cover



etereaa+ eadsy

laccato lucido o opaco
polished or mat lacquered door





etereat. SKIN

rivestimento in pelle ed ecopelle - door with leather and stuff cover



eterea+

reflex

rivestimento vetro riflettente
door with reflecting glass



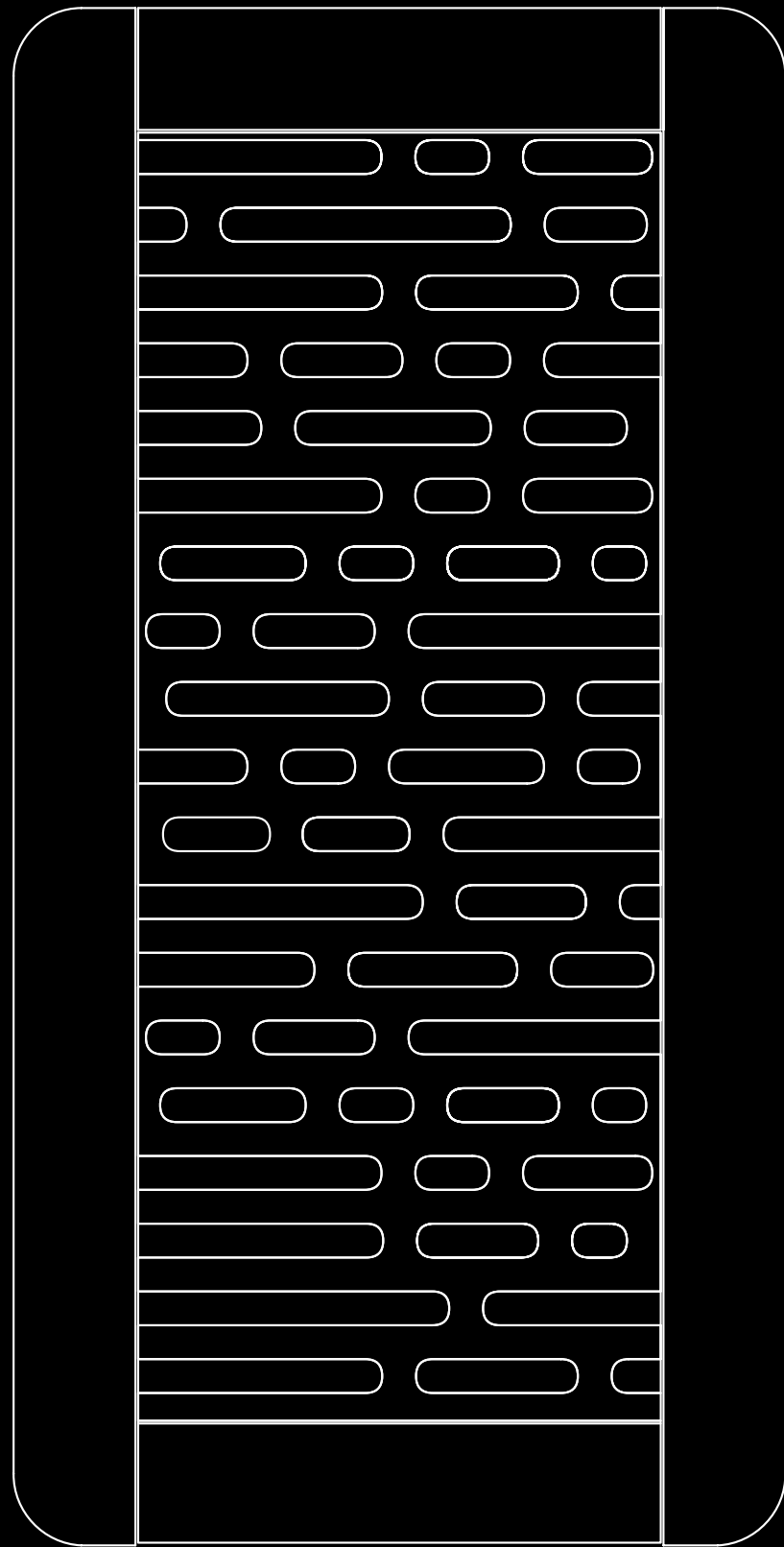

LARGHEZZA MOSTRE INTERNE: 70 MM

MISURA ESTERNO CONTROTELAIO mm 2175

MISURA INTERNO CONTROTELAIO mm 2150

LUCE NETTA PORTA mm 2100

LARGHEZZA MOSTRE ESTERNE: 180 MM



LARGHEZZA MOSTRE INTERNE: 70 MM

MISURA ESTERNO CONTROTELAIO mm 750/850/950/1050

MISURA INTERNO CONTROTELAIO mm 700/800/900/1000

LUCE NETTA PORTA mm 600/700/800/900

LARGHEZZA MOSTRE ESTERNE: 180 MM

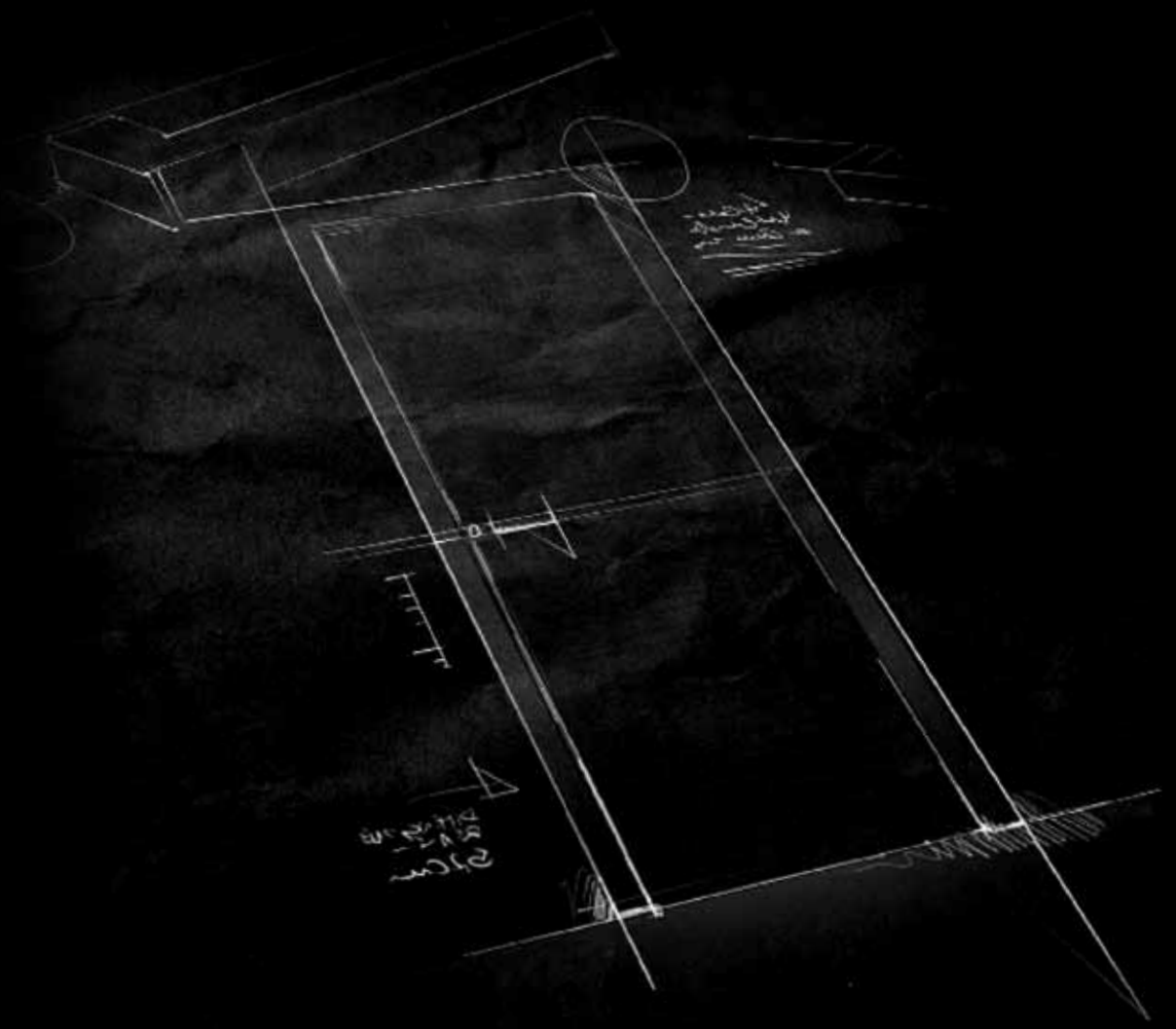

Collezione **CONTEMPORA**

Essenze

*le linee sorprendenti
della contemporaneità*



Marsia

Versione: Cieca
Finitura: Spazzolato laccato bianco
Telaio: Design
Maniglia: Senza foro chiave

Version: Shutter door
Finishing: Brushed white lacquered
Frame: Design
Handles: Without key hole



Marsia

Versione: Cieca
Finitura: Spazzolato laccato RAL 3020
Telaio: Design
Maniglia: Senza foro chiave

Version: Shutter door
Finishing: Brushed lacquered RAL 3020
Frame: Standard
Handles: Without key hole



Marsia

Versione: Cieca
Finitura: Laccato spazzolato RAL 9001
con inserto centrale
Telaio: Design
Maniglia: Con foro chiave

Version: Shutter door
Finishing: Brushed RAL 9001 lacquered
with central insert
Frame: Design
Handles: With key hole



70

Marsia

Versione: Cieca
Finitura: Rovere fumè cera
Telaio: Design
Maniglia: Senza foro chiave

Version: Shutter door
Finishing: Cera fumè oak
Frame: Design
Handles: Without key hole



71

Marsia

Versione: Vetro
Finitura: Rovere
Telaio: Standard
Maniglia: Con foro chiave

Version: Glass
Finishing: Oak
Frame: Standard
Handles: With key hole



72

Marsia

Versione: Cieca con n°.1 inserto in vetro laccato lucido verticale (a richiesta)

Finitura: Rovere bianco cera
Telaio: Design
Maniglia: Con foro chiave

Version: Shutter door with n°.1 vertical insert with laquered (optional)

Finishing: Cera white tinted oak
Frame: Standard
Handles: With key hole



73

Marsia

Versione: Cieca
Finitura: Multinoce
Telaio: Standard
Maniglia: Con foro chiave

Version: Shutter door
Finishing: Multiwalnut
Frame: Standard
Handles: With key hole



74

Marsia

Versione: Cieca
Finitura: Multiciliegio
Telaio: Standard
Maniglia: Con foro chiave

Version: Shutter door
Finishing: Multicherry
Frame: Standard
Handles: With key hole



75

Marsia

Versione: Cieca
Finitura: Multirovere
Telaio: Standard
Maniglia: Con foro chiave

Version: Shutter door
Finishing: Multioak
Frame: Standard
Handles: Without key hole



76

Marsia

Versione: Cieca
Finitura: Multicanaletto
Telaio: Standard
Maniglia: Con foro chiave

Version: Shutter door
Finishing: Multicanaletto
Frame: Standard
Handles: With key hole



77

Demetra

Versione: Cieca
Finitura: Rovere fumè cera
Telaio: Design
Maniglia: Senza foro chiave

Version: Shutter door
Finishing: Slate oak wax
Frame: Design
Handles: Without key hole



Demetra

Versione: Cieca
Finitura: Spazzolato RAL 9002
Telaio: Design
Maniglia: Senza foro chiave

Version: Shutter door
Finishing: Brushed RAL 9002
Frame: Design
Handles: Without key hole



Demetra

Versione: Cieca
Finitura: Wengè
Telaio: design
Maniglia: Con foro chiave

Version: Shutter door
Finishing: Wengè
Frame: Design
Handles: With key hole



Infinita

Versione: Cieca
Finitura: Rovere tortora cera
con 2 inserti verticali cromo satinato
Telaio: Design
Maniglia: Con foro chiave

Version: Shutter door
Finishing: Tortora tinted oak
with 2 satin chrome inserts
Frame: Design
Handles: With key hole



Infinita

Versione: Cieca
Finitura: Rovere moro cera
Telaio: Design
Maniglia: Senza foro chiave

Version: Shutter door
Finishing: Moro tinted oak
Frame: Design
Handles: Without key hole



Infinita

Versione: Cieca
Finitura: Noce Nazionale
Telaio: Standard
Maniglia: Con foro chiave

Version: Shutter door
Finishing: Italian Walnut
Frame: Standard
Handles: With key hole



84

Infinita Variant

Versione: Cieca
Finitura: Rovere
Telaio: Telaio e mostre elisse traverso piatto
Maniglia: Con foro chiave

Version: Shutter door
Finishing: Oak
Frame: Frame and exhibitions across flat ellipse
Handles: With key hole



85

Antea Variant

Versione: Cieca
Finitura: Rovere tinto castagno cera
Telaio: Standard
Maniglia: Con foro chiave

Version: Shutter door
Finishing: Chestnut tinted oak
Frame: Standard
Handles: With key hole



Antea

Versione: Cieca
Finitura: Ciliegio
Telaio: Standard
Maniglia: Con foro chiave

Version: Shutter door
Finishing: Cherry
Frame: Standard
Handles: With key Hole



Antea

Versione: Cieca
Finitura: Rovere bianco cera
Telaio: Standard
Maniglia: Con foro chiave

Version: Shutter door
Finishing: White tinted oak
Frame: Standard
Handles: With key hole



Dalila

Versione: Cieca
Finitura: Rovere
Telaio: Standard
Maniglia: Con foro chiave

Version: Shutter door
Finishing: Rovere
Frame: Standard
Handles: With key hole



90



91

Galaxia 10 Variant

Versione: Cieca
Finitura: Rovere
Telaio: Design
Maniglia: Con foro chiave

Version: Shutter door
Finishing: Oak
Frame: Design
Handles: With key hole



Retrò

Versione: Cieca
Finitura: Rovere tabacco cera
con inserto cromo satinato
Telaio: Design
Maniglia: Con foro chiave

Version: Shutter door
Finishing: Tobacco tinted oak
with satin chrome insert
Frame: Design
Handles: With key hole



Retrò

Versione: Cieca
Finitura: Rovere bianco cera
con inserto cromo satinato
Telaio: Design
Maniglia: Con foro chiave

Version: Shutter door
Finishing: White tinted oak
with satin chrome insert
Frame: Design
Handles: With key hole



Reflex

Versione: Cieca
Finitura: Rovere tortora cera
Telaio: Eteera line
Maniglia: Con foro chiave

Version: Shutter door
Finishing: Tortora tinted oak
Frame: Eteera line
Handles: With key hole



Replay

Versione: Cieca
Finitura: Wengè
Telaio: Eteera line
Maniglia: Con foro chiave

Version: Shutter door
Finishing: Wengè
Frame: Eteera line
Handles: With key hole



Replay

Versione: Cieca
Finitura: Rovere naturale
Telaio: Design
Maniglia: Con foro chiave

Version: Shutter door
Finishing: Rovere naturale
Frame: Design
Handles: With key hole



Pegaso 4

Versione: Cieca
Finitura: Laccato bianco
Telaio: Design
Maniglia: Senza foro chiave

Version: Shutter door
Finishing: White lacquered
Frame: Design
Handles: Without key hole



Pegaso 11

Versione: Cieca
Finitura: Rovere
Telaio: Standard
Maniglia: Con foro chiave

Version: Shutter door
Finishing: Oak
Frame: Standard
Handles: With key hole



100

Pegaso 7

Versione: Cieca
Finitura: Laccato RAL 9002
Telaio: Design
Maniglia: Senza foro chiave

Version: Shutter door
Finishing: Lacquered RAL 9002
Frame: Design
Handles: Without key hole



101



Pegaso 9

Versione: Cieca
Finitura: Laccato RAL 9001
Telaio: Design
Maniglia: Senza foro chiave

Version: Shutter door
Finishing: Lacquered RAL 9001
Frame: Design
Handles: Without key hole

Pegaso 1

Versione: Cieca
Finitura: Rovere bianco cera
Telaio: Standard
Maniglia: Con foro chiave

Version: Shutter door
Finishing: White tinted oak
Frame: Standard
Handles: With key hole



Pegaso 8

Versione: Cieca
Finitura: Ciliegio
Telaio: Standard
Maniglia: Con foro chiave

Version: Shutter door
Finishing: Cherry
Frame: Standard
Handles: With key hole



Pegaso 9

Versione: Cieca
Finitura: Noce Nazionale
Telaio: Standard
Maniglia: Con foro chiave

Version: Shutter door
Finishing: Italian Walnut
Frame: Standard
Handles: With key hole



Pegaso 6

Versione: Cieca
Finitura: Laccato bianco
Telaio: Design
Maniglia: Senza foro chiave

Version: Shutter door
Finishing: White lacquered
Frame: Design
Handles: Without key hole





Versione: Cieca
Finitura: Laccato RAL 1015
Telaio: Design
Maniglia: Senza foro chiave

Version: Shutter door
Finishing: RAL 1015 lacquered
Frame: Design
Handles: Without key hole



Riga 2014

Versione: Cieca
Finitura: Laccato bianco
Telaio: Design
Maniglia: Senza foro chiave

Version: Shutter door
Finishing: White lacquered
Frame: Design
Handles: Without key hole



Riga 2014

Riga 2019

Versione: Cieca
Finitura: Laccato bianco
Telaio: Design
Maniglia: Senza foro chiave

Version: Shutter door
Finishing: White lacquered
Frame: Design
Handles: Without key hole



Riga 2019



Riga 2018

Versione: Cieca
Finitura: Laccato RAL 1013
Telaio: Design
Maniglia: Senza foro chiave

Version: Shutter door
Finishing: RAL 1013 lacquered
Frame: Standard
Handles: Without key hole



Riga 2015

Versione: Cieca
Finitura: RAL 1013
Telaio: Standard
Maniglia: Con foro chiave

Version: Shutter door
Finishing: RAL 1013
Frame: Standard
Handles: With key hole

Linea

Versione: Cieca
Finitura: Laccato bianco con 4 inserti
orizzontali cromo satinato
Telaio: Standard
Maniglia: Con foro chiave

Version: Shutter door
Finishing: white lacquered with n.4 horizontal
satin chrome inserts
Frame: Standard
Handles: With key Hole



Linea

Versione: Cieca
Finitura: Laccato lucido RAL 3020
Telaio: Design
Maniglia: Senza foro chiave

Version: Shutter door
Finishing: High-gloss lacquer RAL 3020
Frame: Design
Handles: Without key hole



Linea

Versione: Cieca
Finitura: Rovere t. castagno cera
Telaio: Standard
Maniglia: Con foro chiave

Version: Shutter door
Finishing: Chestnut tinted oak
Frame: Standard
Handles: With key Hole



112

Linea

Versione: Cieca
Finitura: Anta laminato plastico blu
Telaio: Standard tangananica naturale
Maniglia: Con foro chiave

Version: Shutter door
Finishing: Blue plastic rolled door
Frame: Standard natural tanganyika
Handles: With key hole



113

Mistral Lux

Versione: Vetro
Finitura: Anta alluminio satinato
Telaio: Alluminio satinato
Maniglia: Con foro chiave

Version: Glass
Finishing: Brushed aluminum door
Frame: Brushed aluminum
Handles: With key hole



Mistral

Versione: Cieca
Finitura: Anta laminato plastico bianco
Telaio: Alluminio verniciato bianco

Version: Shutter door
Finishing: White plastic laminated door
Frame: White painted aluminum



Ghibli

Versione: Cieca
Finitura: Marsia wengè con 4 inserti
Telaio: Alluminio satinato
Maniglia: Con foro chiave

Version: Shutter door
Finishing: Marsia wengè with 4 inserts
Frame: Satin aluminum
Handles: With key hole



116

Mimetica

Versione: Cieca TP o SP
Finitura: Fondo levigato per pittura muraria
Telaio: Alluminio estruso a scomparsa
Maniglia: Con foro chiave

Version: Shutter door
Finishing: Base smoothed for building painting
Frame: Sliding aluminium
Handles: With key hole



117



Finitura: Fumè cera

Finishing: Fumè tinted oak

Collezione **CLASS**

Essenze

*lo stile che segna
il gusto di ogni tempo*

Gaia 11

Versione: Cieca
Finitura: Wengè
Telaio: Standard
Maniglia: Con foro chiave

Version: Shutter door
Finishing: Wengè
Frame: Standard
Handle: With key hole



Gaia 26

Versione: Vetro h mm 2400
Finitura: Rovere Fumè Cera
Telaio: Standard mostre a filo luce
Maniglia: Con foro chiave

Version: Glass
Finishing: Fumè tinted oak
Frame: Standard shows light wire
Handle: With key hole



Gaia 25

Versione: Cieca
Finitura: Wengè
Telaio: Standard
Maniglia: Con foro chiave

Version: Shutter door
Finishing: Wengè
Frame: Standard
Handle: With key hole



Gaia 26

Versione: Cieca Con Inserti Vetro Laccato Lucido
Complanare
Finitura: Laccato Bianco
Telaio: Standard con mostre a filo luce
Maniglia: Con foro chiave

Version: Plain leaf with flush Glossy Lacquered
Glass inserts
Finishing: White Lacquered
Frame: Standard flush architraves
Handle: With key hole



Gaia 1

Versione: Cieca
Finitura: Noce Nazionale
Telaio: Standard, mostre a filo luce
Maniglia: Con foro chiave

Version: Shutter door
Finishing: Italian Walnut
Frame: Standard, flush architraves
Handle: With key hole



Gaia 9

Versione: Cieca
Finitura: Wengè
Telaio: Standard
Maniglia: Con foro chiave

Version: Shutter door
Finishing: Wengè
Frame: Standard
Handle: With key hole



Gaia 9V

Versione: Vetro
Finitura: Laccato Bianco
Telaio: Standard
Maniglia: Con foro chiave

Version: Glass door
Finishing: White Lacquered
Frame: Standard
Handle: With key hole



Gaia 10

Versione: Cieca
Finitura: Noce Nazionale
Telaio: Standard
Maniglia: Con foro chiave

Version: Shutter door
Finishing: Italian Walnut
Frame: Standard
Handle: With key hole



128

Gaia 10V

Versione: Vetro
Finitura: Rovere bianco cera
Telaio: Standard
Maniglia: Con foro chiave

Version: Glass door
Finishing: White tinted oak
Frame: Standard
Handle: With key hole



129

Cometa 18

Versione: Cieca
Finitura: RAL 9001
Telaio: Design
Maniglia: Senza foro chiave

Version: Shutter door
Finishing: RAL 9001
Frame: Design
Handle: Without key hole



Cometa 16

Versione: Cieca
Finitura: Laccato RAL 9001
Telaio: Standard
Maniglia: Senza foro chiave

Version: Shutter door
Finishing: Lacquered RAL 9001
Frame: Standard
Handle: Without key hole



Cometa 6

Versione: Cieca
Finitura: Laccato Bianco
Telaio: Design
Maniglia: Senza foro chiave

Version: Shutter door
Finishing: White Lacquered
Frame: Design
Handle: Without key hole



Stella 6

Versione: Cieca
Finitura: Laccato RAL 1013
Telaio: Standard
Maniglia: Con foro chiave

Version: Shutter door
Finishing: RAL 1013 Laquere
Frame: Standard
Handle: With key hole

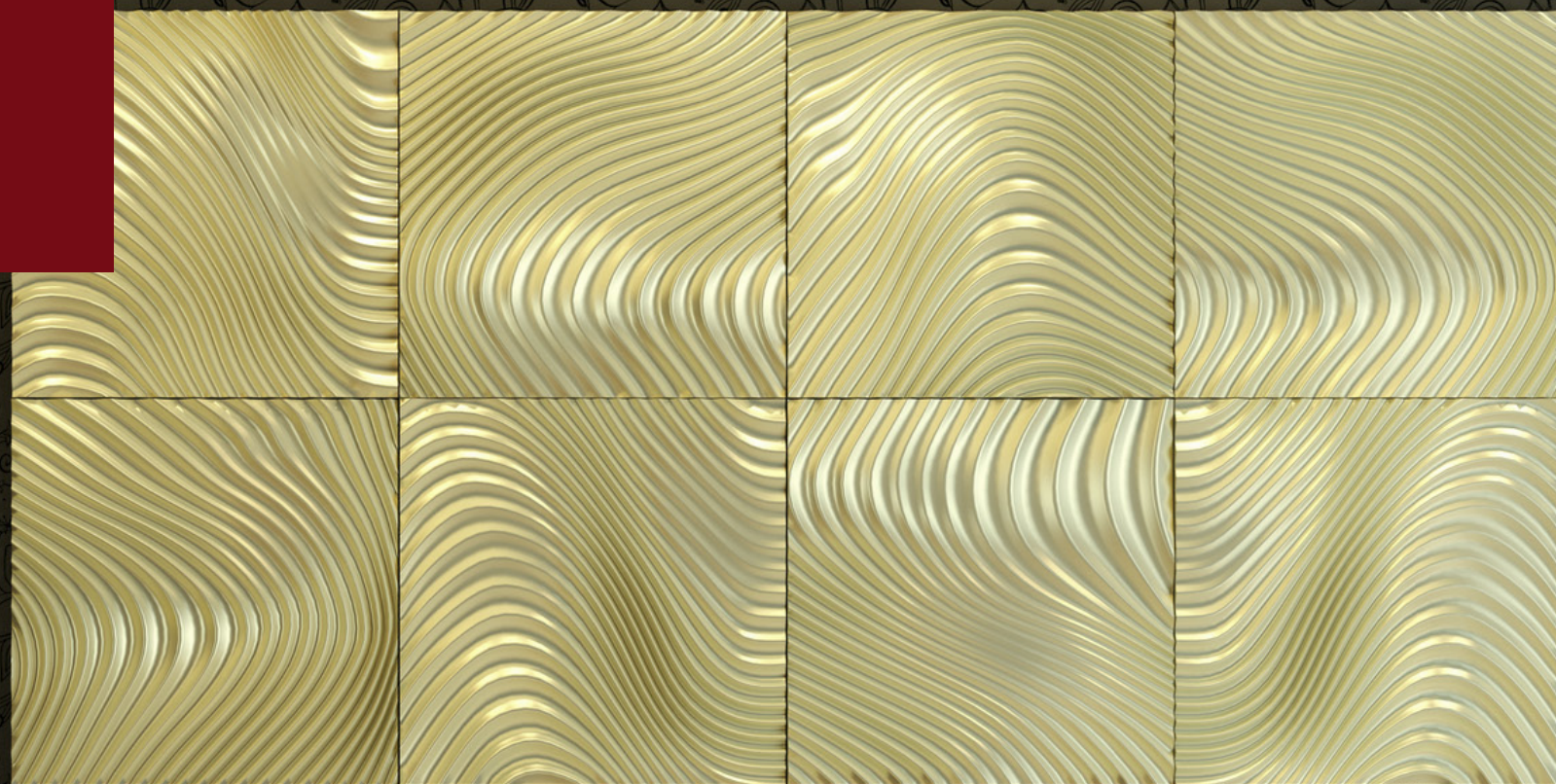

Stella 6

Versione: Duan
Finitura: Laccato RAL 1013
Telaio: Standard
Maniglia: Senza foro chiave

Version: Duan
Finishing: Lacquered RAL 1013
Frame: Standard
Handle: Without key hole



Stella 17

Versione: Cieca
Finitura: Laccato RAL 9002
Telaio: Design
Maniglia: Senza foro chiave

Version: Shutter door
Finishing: Lacquered RAL 9002
Frame: Design
Handle: Without key hole



Stella 2

Versione: Vetro
Finitura: Laccato Bianco
Telaio: Ellisse
Maniglia: Con foro chiave

Version: Glass door
Finishing: White Lacquered
Frame: Ellisse
Handle: With key hole



Novastella 13

Versione: Cieca
Finitura: Laccato Bianco
Telaio: Ellisse
Maniglia: Con foro chiave

Version: Shutter door
Finishing: White Lacquered
Frame: Ellisse
Handle: With key hole



Orizon 2

Versione: Cieca
Finitura: Rovere castagno cera
Telaio: Standard, mostre ellisse, traverso piatto
Maniglia: Con foro chiave

Version: Shutter door
Finishing: chestnut tinted oak
Frame: Standard, architraves ellisse, flat transom
Handle: With key hole

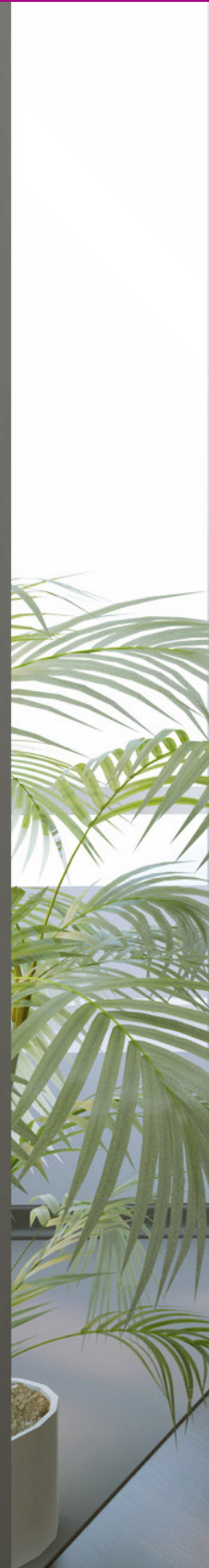

Orizon 4

Versione: Vetro
Finitura: Laccato Bianco
Telaio: Standard
Maniglia: Con foro chiave

Version: Glass door
Finishing: White Lacquered
Frame: Standard
Handle: With key hole



Orizon 3

Versione: Cieca
Finitura: Rovere
Telaio: Standard, mostre ellisse, traverso piatto
Maniglia: Con foro chiave

Version: Shutter door
Finishing: Oak
Frame: Standard, architraves ellisse, flat transom
Handle: With key hole



NovaResidence 1

Versione: Cieca
Finitura: Rovere
Telaio: Standard
Maniglia: Con foro chiave

Version: Shutter door
Finishing: Oak
Frame: Standard
Handle: With key hole



NovaCastello

Versione: Cieca
Finitura: Ciliegio
Telaio: Standard
Maniglia: Con foro chiave

Version: Shutter door
Finishing: Cherry
Frame: Standard
Handle: Standard



Domus

Versione: Vetro
Finitura: Laccato bianco
Telaio: Ellisse, mostre ellisse
Maniglia: Con foro chiave

Version: Vetro
Finishing: White lacquered
Frame: Ellisse
Handle: With key hole



Domus

Versione: Cieca
Finitura: Noce Nazionale
Telaio: Standard
Maniglia: Con foro chiave

Version: Shutter door
Finishing: Italian Walnut
Frame: Standard
Handle: With key hole



Novatorre

Versione: Cieca
Finitura: Ciliegio
Telaio: Standard
Maniglia: Con foro chiave

Version: Shutter door
Finishing: Cherry
Frame: Standard
Handle: With key hole



150

Novatorre

Versione: Vetro
Finitura: Rovere
Telaio: Standard
Maniglia: Con foro chiave

Version: Glass door
Finishing: Oak
Frame: Standard
Handle: With key hole



151

Prestige

Versione: Cieca
Finitura: Ciliegio
Telaio: Standard
Maniglia: Con foro chiave

Version: Shutter door
Finishing: Cherry
Frame: Standard
Handle: With key hole



152

Prestige

Versione: Cieca
Finitura: Rovere
Telaio: Standard, mostre ellisse, traverso piatto
Maniglia: Con foro chiave

Version: Shutter door
Finishing: Oak
Frame: Standard, architraves ellisse, flat transom
Handle: With key hole



153

Prestige

Versione: Vetro
Finitura: Noce Nazionale
Telaio: Standard
Maniglia: Con foro chiave

Version: Glass door
Finishing: Italian Walnut
Frame: Standard
Handle: Standard



Prestige

Versione: Cieca
Finitura: Laccato Bianco
Telaio: Standard
Maniglia: Con foro chiave

Version: Shutter door
Finishing: White Lacquered
Frame: Standard
Handle: With key hole



Versione: Cieca
Finitura: Rovere
Telaio: Standard
Maniglia: Con foro chiave

Version: Shutter door
Finishing: Oak
Frame: Standard
Handle: With key hole



Versione: Cieca
Finitura: Noce Nazionale
Telaio: Ellisse
Maniglia: Con foro chiave

Version: Shutter door
Finishing: Italian Walnut
Frame: Ellisse
Handle: With key hole



Palatina

Versione: Vetro
Finitura: Laccato Bianco
Telaio: Standard
Maniglia: Con foro chiave

Version: Glass door
Finishing: White Lacquered
Frame: Standard
Handle: With key hole



Palatina

Versione: Cieca
Finitura: Ciliegio
Telaio: Ellisse
Maniglia: Con foro chiave

Version: Shutter door
Finishing: Cherry
Frame: Ellisse
Handle: With key hole



Casale

Versione: Cieca
Finitura: Noce Nazionale
Telaio: Ellisse
Maniglia: Con foro chiave

Version: Shutter door
Finishing: Italian Walnut
Frame: Ellisse
Handle: With key hole



160

Casale

Versione: Vetro
Finitura: Rovere
Telaio: Standard
Maniglia: Con foro chiave

Version: Glass door
Finishing: Oak
Frame: Standard
Handle: With key hole



161

Collezione **REI**

Le porte dell'ospitalità

Anta spessore 45 mm

Certificato di resistenza al fuoco secondo la norma fire resistant certificate Cnvvf/cci uni 9723

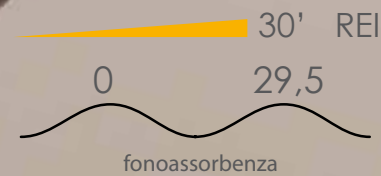

Certificato di Fonoisolazione soundproof certificate Uni 8270: Rw=dB 29.5

REI 30 SERIE S3

Porta interna in legno mod. "REI 30 SERIE S3" con telaio in legno lamellare impiallacciato, mostre telescopiche sui 2 lati da mm.70x10x19 (estensibilità max mm 20) in multistrato impiallacciato; anta da mm. 45 circa avente intelaiatura perimetrale in legno massello bordato e struttura interna coibentata con materiale ignifugo fonoisolante rivestito sulle due facce con fogli in fibra di legno ignipas mm.6 impiallacciati con multilaminare e/o essenza di legno pregiato (carta melaminica bianca per versione laccata) e verniciati a finitura opaca. Completa di n.3 cerniere tipo "anuba" registrabili diametro mm.16 doppio gambo, guarnizione acustica, guarnizione intumescente autoespandente e accessori d'uso.

La porta a richiesta può essere corredata di:

serratura tipo "ANTIPANICO" ottonata con cilindro yale chiave/pomello completo di segnalatore di presenza e sistema EMK a chiavi maestre (una chiave di emergenza ed una di servizio), paraspiffero a ghigliottina, chiudiporta idraulico aereo idraulico (esterno anta) e kit maniglia Hotel.

Wooden door for interiors mod. "REI30 SERIE S3" with veneered laminated wood frame, telescopic architraves mm 70x10x19 on both sides (max extensibility 20mm) made with veneered plywood; leaf of about 45 mm thickness, with veneered solid wood edges, filled with fireproof/soundproof material, covered on the two faces by IGNIPAS fiberboard panels of 6 mm thickness, veneered with multilaminar wood and/or high quality wood (melaminic paper for lacquered version) and varnished with mat varnish. Fitted with 3 adjustable hinges ("anuba" type diam. 16 mm double pin), soundproof rubber seal, fireproof seal and usual accessories.

On demand the door can have:

Brassed ANTIPANIC lock "yale" type with key/thumbturn cylinder having occupancy indicator and EMK system with master key (one emergency key and one service key), concealed bottom threshold, external overhead hydraulic door closer, and Hotel handle kit.



Chiudiporta esterno



Paraspiffero a ghigliottina

Anta REI 30 mm 2100x600/700/800/850/900

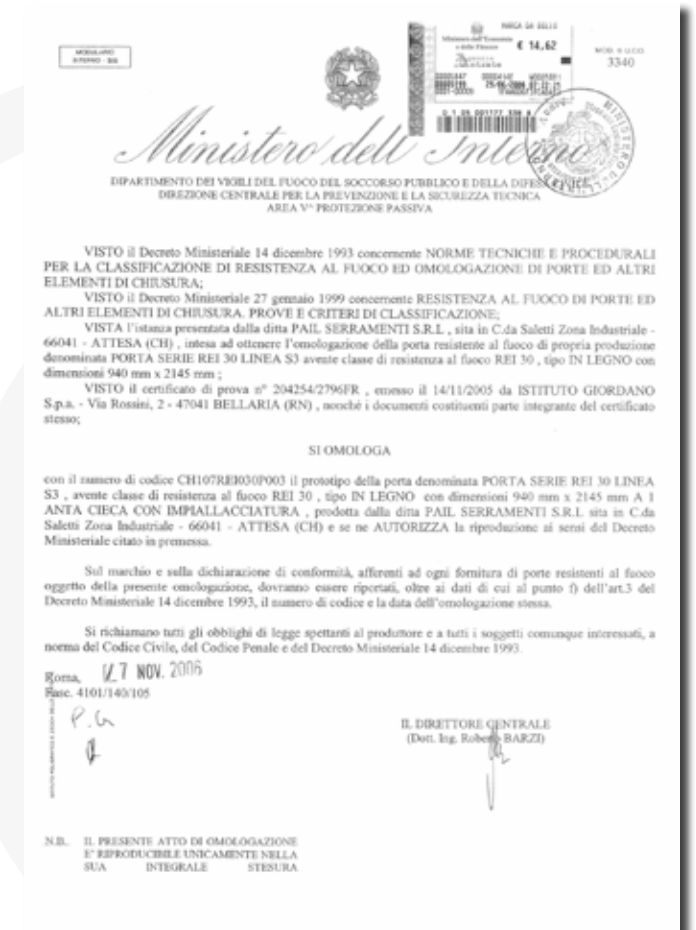
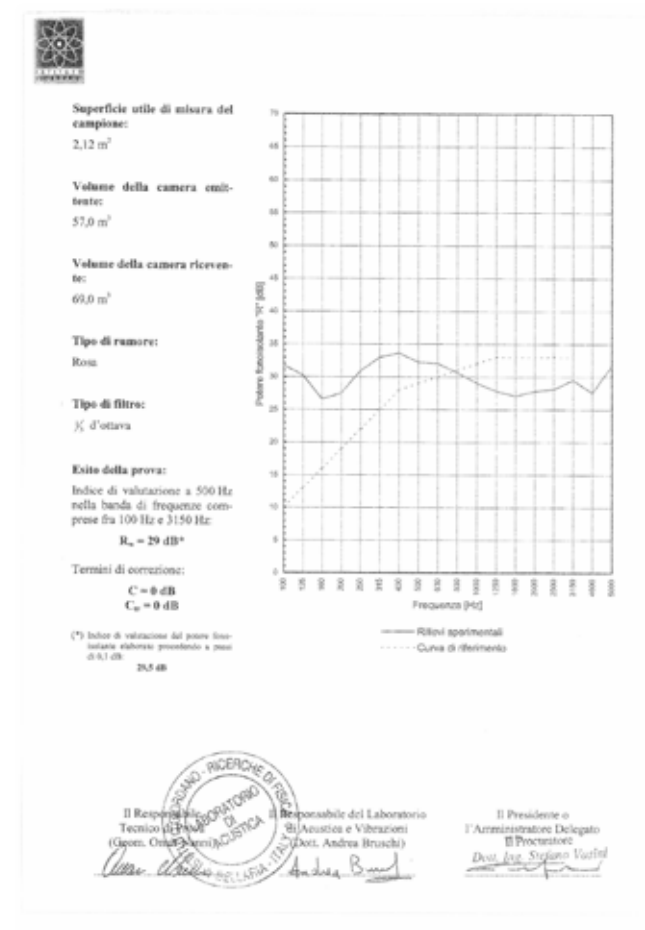

**Anta spessore 63 mm.
con guarnizione**

Certificato di resistenza al fuoco secondo la norma *fire resistant certificate Cnvvf/ccl uni 9723*

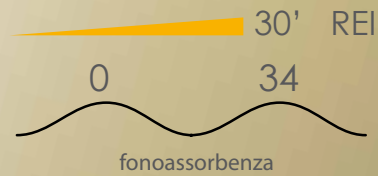

Certificato di Fonoisolazione *soundproof certificate Uni 8270: Rw=dB 34.0*

REI 30 HOTEL S5

Porta interna in legno mod. "REI 30 HOTEL S5" con telaio in legno lamellare impiallacciato, mostre telescopiche sui 2 lati da mm.70x10x19 (estensibilità max mm 20) in multistrato impiallacciato; anta da mm. 63 circa avente intelaiatura perimetrale in legno massello bordato e struttura interna coibentata con materiale ignifugo fonoisolante rivestito sulle due facce con fogli in sibrato di legno mdf mm.6 impiallacciati con multilaminare e/o essenza di legno pregiato (carta melaminica bianca per versione laccata) e verniciati a finitura opaca. Completa di n.3 cerniere tipo "anuba" registrabili diametro mm.16 doppio gambo, doppia guarnizione acustica, guarnizione intumescente autoespandente e accessori d'uso.

La porta a richiesta può essere corredata di:

serratura tipo "ANTIPANICO" ottonata con cilindro yale chiave/pomello completo di segnalatore di presenza e sistema EMK a chiavi maestre (una chiave di emergenza ed una di servizio), paraspiffero a ghigliottina acustico con doppio azionamento, chiudiporta idraulico a scomparsa (incassato nell'anta) e kit maniglia Hotel.

Wooden door for interiors mod. "REI30 HOTEL S5" with veneered laminated wood frame , telescopic architraves mm 70x10x19 on both sides (max extensibility 20mm) made with veneered plywood; leaf of about 63 mm thickness, with veneered solid wood edges , filled with fireproof/soundproof material, covered on the two faces by medium density fiberboard panels MDF of 6 mm thickness, veneered with multilaminar wood and/or high quality wood (melaminic paper for lacqured version) and varnished with mat varnish . Fitted with 3 adjustable hinges ("anuba" type diam. 16 mm double pin), double soundproof rubber seal, fireproof seal and usual accessories.

On demand the door can have:

Brassed ANTIPANICO lock "yale" type with key/thumbturn cylinder having occupancy indicator and EMK system with master key (one emergency key and one service key), soundproof double action concealed bottom threshold , concealed overhead hydraulic door closer , and Hotel handle kit.



Chiudiporta a scomparsa

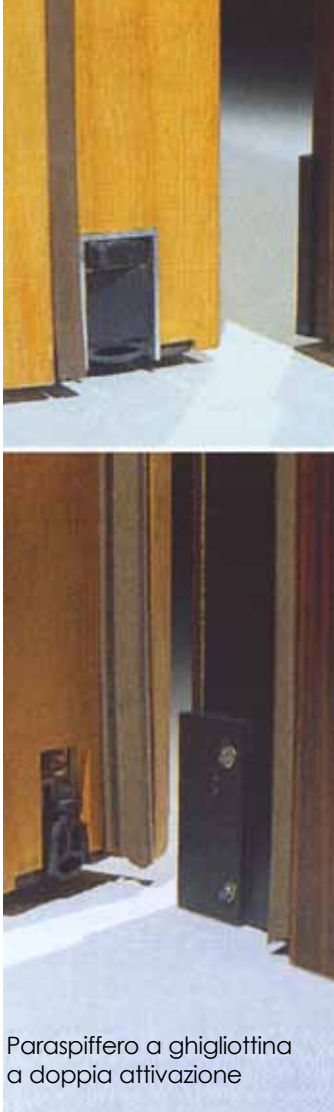

Paraspiffero a ghigliottina a doppia attivazione

Anta REI 30 mm 2100x600/700/800/850/900

CSI

RICERCA DEL POTERE FONOISOLANTE

OGGETTO DI PROVA: Porta INGLESA SERIE HOTEL

IDENTIFICAZIONE DELL'ELEMENTO DI PROVA: L,78 m²

ES = LIVELLO MEDIO DI FREQUENZA SONORA NELLA CAMERA DESTINATA

ES = LIVELLO MEDIO DI FREQUENZA SONORA NELLA CAMERA DESTINATA

D = ES - LE = ISOLAMENTO ADESSIVO

T = TEMPO MEDIO DI RIVVERBERAZIONE NELLA CAMERA DESTINATA

F = 30 log 18 x T / (0,16 x V)

VOLUME DELLA CAMERA DESTINATA: 31,00 m³

R = E + F = POTERE FONOISOLANTE

INDICE D'ISOLAZIONE IN dB: 34,0

FREQ. Hz	ES	LE	D	T	F	R	
125	12,30	21,50	43,20	29,3	1,5	+4,9	31,4
175	14,60	20,40	31,20	20,3	2,18	-3,5	26,4
250	14,10	20,50	31,30	20,7	2,75	-3,3	27,4
350	9,90	22,40	32,50	21,4	3,88	-3,9	27,5
500	14,90	22,40	32,50	21,4	5,31	-4,9	28,4
700	13,30	23,00	34,00	22,1	7,28	-5,4	29,1
1000	9,10	24,80	37,30	27,5	10,25	-5,7	30,1
1400	6,40	24,80	37,30	27,5	14,15	-6,0	31,4
2000	2,30	25,10	47,10	39,0	21,34	-5,9	32,1
2800	2,30	25,10	47,10	39,0	29,7	-6,2	33,5
3800	2,80	25,20	45,10	38,1	41,15	-6,0	32,1
5000	3,50	24,30	42,30	43,4	57,01	-6,6	32,8
6800	4,40	25,20	42,70	42,5	81,34	-6,8	32,7
9000	5,20	24,30	42,30	44,0	111,37	-6,8	32,9
12000	6,00	25,20	42,30	42,9	148,02	-7,3	32,9
16000	6,80	25,10	42,20	41,9	203,02	-7,5	34,4
20000	7,70	25,10	42,20	41,9	278,02	-7,5	34,4

GRUPPO IMQ

Ministero del *Interno*

DIPARTIMENTO DEI VIGILI DEL FUOCO DEL SOCCORSO PUBBLICO E DELLA DIFESA CIVILE
DIREZIONE CENTRALE PER LA PREVENZIONE E LA SICUREZZA TECNICA
AREA V° - PROTEZIONE PASSIVA

VISTO il Decreto Ministeriale 21 giugno 2004 concernente NORME TECNICHE E PROCEDURALI PER LA CLASSIFICAZIONE DI RESISTENZA AL FUOCO ED OMOLOGAZIONE DI PORTE ED ALTRI ELEMENTI DI CHIUSURA;

VISTO il Decreto Ministeriale 27 gennaio 1999 concernente RESISTENZA AL FUOCO DI PORTE ED ALTRI ELEMENTI DI CHIUSURA. PROVE E CRITERI DI CLASSIFICAZIONE;

VISTA l'istanza presentata dalla ditta PAIL SERRAMENTI S.R.L., sita in C.da Saletti Zona Industriale - 66041 - ATTESA (CH), imessa ad ottenere l'omologazione della porta resistente al fuoco di propria produzione denominata PORTA SERIE HOTEL avente classe di resistenza al fuoco REI 30 , tipo IN LEGNO con dimensioni 1047 mm x 2201 mm ;

VISTO il certificato di prova n° CSI1033RF , emesso il 07/02/2003 da C.S.I. S.p.a. - Viale Lombardia, 20 - 20021 BOLLATE (MI), nonché i documenti costituenti parte integrante del certificato stesso;

SI OMOLOGA

con il numero di codice CH107REI30P002 il prototipo della porta denominata PORTA SERIE HOTEL , avente classe di resistenza al fuoco REI 30 , tipo IN LEGNO con dimensioni 1047 mm x 2201 mm A 1 ANTA CIECA CON IMPIALLACCIATURA , prodotta dalla ditta PAIL SERRAMENTI S.R.L. sita in C.da Saletti Zona Industriale - 66041 - ATTESA (CH) e se ne AUTORIZZA la riproduzione ai sensi del Decreto Ministeriale citato in premessa.

Sul marchio e sulla dichiarazione di conformità, afferenti ad ogni fornitura di porte resistenti al fuoco oggetto della presente omologazione, dovranno essere riportati, oltre ai dati di cui al punto b) dell'art.2 del Decreto Ministeriale 21 giugno 2004, il numero di codice e la data dell'omologazione stessa.

Si richiamano tutti gli obblighi di legge spettanti al produttore e a tutti i soggetti comunque interessati, a norma del Codice Civile, del Codice Penale e del Decreto Ministeriale 21 giugno 2004.

Roma, - 2 NOV. 2010
Fasc. 4101/140/105

Il Direttore Centrale
DATTILO

N.B. IL PRESENTE ATTO DI OMOLOGAZIONE È RIPRODUCIBILE UNICAMENTE NELLA SUA INTEGRALE STESURA

Anta spessore 59 mm.
con guarnizione

Certificato di resistenza al fuoco secondo la norma
fire resistant certificate
UNI EN 1634-1:2001

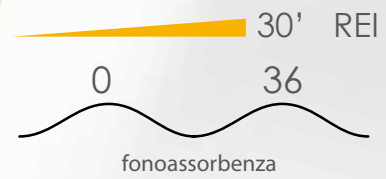

Certificato di Fonoisolazione
soundproof certificate
Rw=dB 36.0

REI 30 ETEREA

Porta interna in legno mod. "REI 30 ETEREA" realizzata con sistema "CONVERT" (pannello esterno estraibile), telaio in legno lamellare impiallacciato, mostre esterne fisse da mm 100x10 e mostre telescopiche lato interno da mm.70x10x19 (estensibilità max mm 10) in multistrato impiallacciato; anta da mm. 59 circa costituita da un pannello "A" tamburato da mm 45 avente intelaiatura perimetrale in legno massello bordato e struttura interna coibentata con materiale ignifugo fonoisolante rivestito sulle due facce con fogli in sibrato di legno mdf mm.6 impiallacciati con multilaminare e/o essenza di legno pregiato (carta melaminica bianca per versione laccata) e verniciati a finitura opaca; più un pannello "B" in sibrato di legno mdf da mm 14 impiallacciato con multilaminare e/o essenza di legno pregiato o rivestito con materiali alternativi (tessuto, pelle, laccatura) i due pannelli sono accoppiati mediante sistema "convert" brevettato, che permette anche l'eventuale cambio del pannello "B". Completa di n.4 cerniere tipo "bandella" registrabili diametro mm.16 doppio gambo, doppia guarnizione acustica, guarnizione intumescente autoespandente e accessori d'uso.

La porta a richiesta può essere corredata di:

seratura tipo "ANTIPANICO" ottonata con cilindro yale chiave/pomello completo di segnalatore di presenza e sistema EMK a chiavi maestre (una chiave di emergenza ed una di servizio), paraspiffero a ghigliottina acustico con doppio azionamento, chiudiporta idraulico a scomparsa (incassato nell'anta) e kit maniglia Hotel.

Wooden door for interiors mod. "REI30 ETEREA" realized with "CONVERT" system (removable external panel), with veneered laminated wood frame, fixed external architraves of mm 100x10 and internal side with telescopic architraves mm 70x10x19 (max extensibility 10mm) made with veneered plywood; leaf of about 59 mm thickness made by a main panel "A" of about mm45 thickness having veneered solid wood edges and filled with fireproof/soundproof material, covered on the two faces by medium density fiberboard panels MDF of 6 mm thickness, veneered with multilaminar wood and/or high quality wood (melaminic paper for lacquered version) and varnished with mat varnish; we also have a "B" panel made with medium density fiberboard -MDF of 14 mm thickness veneered with multilaminar wood and/or high quality wood or covered with alternative material (fabric, leather, lacquered); the two panels are fastened together by a patented "convert" system that enable to eventually change the panel "B" Fitted with 4 adjustable hinges ("bandella" type diam. 16 mm double pin), double soundproof rubber seal, fireproof seal and usual accessories.

On demand the door can have:

Brassed ANTIPANIC lock "yale" type with key/thumbturn cylinder having occupancy indicator and EMK system with master key (one emergency key and one service key), soundproof double action concealed bottom threshold, concealed overhead hydraulic door closer, and Hotel handle kit.



Kit maniglia hotel quadra cromata su placca



Chiudiporta a scomparsa

Anta REI 30 mm 2100x600/700/800/850/900



Ministero dell'Interno

DIPARTIMENTO DEI VIGILI DEL FUOCO DEL SOCCORSO PUBBLICO E DELLA EMERGENZA CIVILE
DIREZIONE CENTRALE PER LA PREVENZIONE E LA SICUREZZA TECNICA
AREA V - PROTEZIONE PASSIVA

VISTO il Decreto Ministeriale 21 giugno 2004 concernente NORME TECNICHE E PROCEDURALI PER LA CLASSIFICAZIONE DI RESISTENZA AL FUOCO ED OMOLOGAZIONE DI PORTE ED ALTRI ELEMENTI DI CHIUSURA;

VISTA l'istanza presentata dalla ditta PAIL SERRAMENTI S.R.L., sita in C.da Salsiti Zona Industriale - 66041 - ATTESA (CH), intesa ad ottenere l'omologazione della porta resistente al fuoco di propria produzione denominata PORTA REI 30 ETEREA S5 avente classe di resistenza al fuoco EI_s 30, tipo IN LEGNO con dimensioni 930 mm x 2140 mm;

VISTO il certificato di prova n° 251808/3100FR, emesso il 19/02/2009 da ISTITUTO GIORDANO S.p.a. - Via Rossini, 2 - 47041 BELLARIA (RN), nonché i documenti costituenti parte integrante del certificato stesso;

SI OMOLOGA

con il numero di codice CH107RE030P004 il prototipo della porta denominata PORTA REI 30 ETEREA S5, avente classe di resistenza al fuoco EI_s 30, tipo IN LEGNO con dimensioni 930 mm x 2140 mm A 1 ANTA CIECA, prodotta dalla ditta PAIL SERRAMENTI S.R.L. sita in C.da Salsiti Zona Industriale - 66041 - ATTESA (CH) e se ne AUTORIZZA la riproduzione ai sensi del Decreto Ministeriale citato in premessa.

La validità dell'omologazione relativa al certificato di cui in premessa viene estesa alla famiglia di porte resistenti al fuoco in base ai criteri dettati dal Decreto Ministeriale 21 giugno 2004 e con esclusiva utilizzazione di materiali aventi tutte le caratteristiche fisico-chimiche identiche a quelli impiegati nella produzione della porta resistente al fuoco denominata PORTA REI 30 ETEREA S5, con dimensioni che possono variare come di seguito riportato:

Larghezza x altezza (mm)	Per larghezza ed altezza entrambe in diminuzione		Per larghezza ed altezza entrambe in aumento	
	a	b	a	b
564 x 1.786	930	2.140	930	2.140
632 x 1.815	988	2.169	988	2.169
700 x 1.750	986	2.104	986	2.104
768 x 1.750	1.030	2.104	1.030	2.104
836 x 1.750	1.074	2.104	1.074	2.104
904 x 1.750	1.118	2.104	1.118	2.104

N.B. IL PRESENTE ATTO DI OMOLOGAZIONE È RIPRODUCIBILE UNICAMENTE NELLA SUA INTEGRALE STESURA

Codice di omologazione: CH107RE030P004

pag. 1

Collezione **ALISEA**

Decorati



*tra rigore e originalità
preziose soluzioni innovative*

LN

Versione: Cieca
Finitura: Bianco con 1 inserto centrale
cromo satinato
Telaio: Standard
Maniglia: Con foro chiave

Version: Shutter door
Finishing: White with 1 central
satin chrome insert
Frame: Standard
Handle: With key hole



LN

Versione: Vetro Pescara
Finitura: Wengè
Telaio: Standard
Maniglia: Con foro chiave

Version: Pescara glass door
Finishing: Wengè
Frame: Standard
Handle: With key hole



174

LN

Versione: Cieca
Finitura: Crema con 1 inserto centrale
cromo satinato
Telaio: Design
Maniglia: Senza foro chiave

Version: Shutter door
Finishing: cream with 1 central
satin chrome insert
Frame: Design
Handle: Without key hole



175



MS

Versione: Cieca
Finitura: Rovere Provenza
Telaio: Eteera Line
Maniglia: Senza foro chiave

Version: Shutter door
Finishing: Oak Provence
Frame: Eteera Line
Handle: Without key hole



MS

Versione: Cieca
Finitura: Rovere mocaccino
Telaio: Design
Maniglia: Senza foro chiave

Version: Shutter door
Finishing: Mocaccino
Frame: Design
Handle: Without key hole



MS

Versione: Cieca
Finitura: Rovere Moka
Telaio: Design
Maniglia: Senza foro chiave

Version: Shutter door
Finishing: Moka Oak
Frame: Design
Handle: Without key hole



MS

Versione: Cieca
Finitura: Bianco brushed
Telaio: Eteera Line
Maniglia: Senza foro chiave

Version: Shutter door
Finishing: White Brushed
Frame: Eteera Line
Handle: Without key hole



MS

Versione: Cieca
Finitura: Wengè con 4 inserti orizzontali
cromo satinato
Telaio: Standard
Maniglia: Con foro chiave

Version: Shutter door
Finishing: Wengè with 4 horizontal
satin chrome inserts
Frame: Standard
Handle: With key hole



MS

Versione: Cieca
Finitura: Lino delavè con 1 inserto
centrale cromo satinato
Telaio: Design
Maniglia: Senza foro chiave

Version: Shutter door
Finishing: Delavè linen with 1 central
satin chrome insert
Frame: Design
Handle: Without key hole



MS

Versione: Cieca
Finitura: Rovere Naturale
Telaio: Design
Maniglia: Senza foro chiave

Version: Shutter door
Finishing: Natural Oak
Frame: Design
Handle: Without key hole



MS

Versione: Cieca
Finitura: Lino Kaki
Telaio: Eteera Line
Maniglia: Senza foro chiave

Version: Shutter door
Finishing: Khaki linen
Frame: Eteera Line
Handle: Without key hole



MS

Versione: Cieca
Finitura: Rovere city con 1 inserto
centrale cromo satinato
Telaio: Design
Maniglia: Senza foro chiave

Version: Shutter door
Finishing: Oak city with 1 central
satin chrome insert
Frame: Design
Handle: Without key hole



MS

Versione: Cieca
Finitura: Bianco Shangai
Telaio: Design
Maniglia: Con foro chiave

Version: Shutter door
Finishing: White Shangai
Frame: Design
Handle: With key hole



MS

Versione: Cieca
Finitura: Bianco Scacchi
Telaio: Design
Maniglia: Con foro chiave

Version: Shutter door
Finishing: White Chess
Frame: Design
Handle: With key hole



MS

Versione: Cieca
Finitura: Noce Nazionale
Telaio: Standard
Maniglia: Con foro chiave

Version: Shutter door
Finishing: Italian Walnut
Frame: Standard
Handle: With key hole



MS

Versione: Cieca
Finitura: Bianco frassino
Telaio: Design
Maniglia: Senza foro chiave

Version: Shutter door
Finishing: White ash
Frame: Design
Handle: Without key hole



INF

Versione: Cieca
Finitura: Rovere Naturale
Telaio: Design
Maniglia: Senza foro chiave

Version: Shutter door
Finishing: Natural Oak
Frame: Design
Handle: Without key hole



INF

Versione: Cieca
Finitura: Lino Delavè
Telaio: Design
Maniglia: Senza foro chiave

Version: Shutter door
Finishing: Delavè Linen
Frame: Design
Handle: Without key hole



INF

Versione: Cieca
Finitura: Noce Nazionale
Telaio: Standard
Maniglia: Con foro chiave

Version: Shutter door
Finishing: Italian Walnut
Frame: Standard
Handle: With key hole



INF

Versione: Cieca
Finitura: Rovere Provenza
Telaio: Design
Maniglia: Senza foro chiave

Version: Shutter door
Finishing: Oak Provence
Frame: Design
Handle: Without key hole



INF

Versione: Cieca
Finitura: Noce Biondo
Telaio: Standard
Maniglia: Con foro chiave

Version: Shutter door
Finishing: Medium Walnut
Frame: Standard
Handle: With key hole



DMT

Versione: Cieca
Finitura: Rovere Moka
Telaio: Design
Maniglia: Senza foro chiave

Version: Shutter door
Finishing: Moka Oak
Frame: Design
Handle: Without key hole



DMT

Versione: Cieca
Finitura: Ciliegio
Telaio: Ellisse
Maniglia: Con foro chiave

Version: Shutter door
Finishing: Cherry
Frame: Ellisse
Handle: With key hole



DMT

Versione: Cieca
Finitura: Rovere Sbiancato
Telaio: Standard
Maniglia: Con foro chiave

Version: Shutter door
Finishing: White Oak
Frame: Standard
Handle: With key hole



DMT

Versione: Cieca
Finitura: Rovere Naturale
Telaio: Design
Maniglia: Senza foro chiave

Version: Shutter door
Finishing: Natural Oak
Frame: Design
Handle: Without key hole



DMT

Versione: Cieca
Finitura: Lino Kaki
Telaio: Design
Maniglia: Senza foro chiave

Version: Shutter door
Finishing: Khaki linen
Frame: Design
Handle: Without key hole



DMT

Versione: Cieca
Finitura: Bianco Frassino
Telaio: Design
Maniglia: Senza foro chiave

Version: Shutter door
Finishing: White Ash
Frame: Design
Handle: Without key hole



DMT

Versione: Cieca
Finitura: Rovere moka
Telaio: Design
Maniglia: Senza foro chiave

Version: Shutter door
Finishing: Moka tinted oak
Frame: Design
Handle: Without key hole



RPY

Versione: Cieca
Finitura: Rovere moka
Telaio: Design
Maniglia: Con foro chiave

Version: Shutter door
Finishing: Moka tinted oak
Frame: Design
Handle: With key hole



RTO

Versione: Cieca
Finitura: Rovere mocaccino
Telaio: Design
Maniglia: Con foro chiave

Version: Shutter door
Finishing: Mocaccino tinted oak
Frame: Design
Handle: With key hole



RFX

Versione: Cieca
Finitura: Lino delavè
Telaio: Design
Maniglia: Con foro chiave

Version: Shutter door
Finishing: Lino delavè
Frame: Design
Handle: With key hole



LA27V

Versione: Vetro
Finitura: Lino delavè
Telaio: Standard mostre design
Maniglia: Con foro chiave

Version: Shutter door
Finishing: Lino
Frame: Design
Handle: With key hole



LA1V

Versione: Vetro
Finitura: Rovere naturale
Telaio: Standard
Maniglia: Con foro chiave

Version: Glass
Finishing: Rovere naturale
Frame: Standard
Handle: With key hole



208

LA1C

Versione: Cieca
Finitura: Rovere naturale
Telaio: Standard
Maniglia: Con foro chiave

Version: Shutter door
Finishing: Rovere naturale
Frame: Standard
Handle: With key hole



209

LA9V

Versione: Vetro
Finitura: Rovere city
Telaio: Standard mostre filo luce
Maniglia: Con foro chiave

Version: Glass
Finishing: Rovere city
Frame: Standard flush architrave
Handle: With key hole



LA9C

Versione: Cieca
Finitura: Wengè
Telaio: Standard mostre filo luce
Maniglia: Con foro chiave

Version: Shutter door
Finishing: Wengè
Frame: Standard flush architrave
Handle: With key hole



LA10C

Versione: Cieca
Finitura: Rovere naturale
Telaio: Standard mostre filo luce
Maniglia: Con foro chiave

Version: Shutter door
Finishing: Rovere naturale
Frame: Standard flush architrave
Handle: With key hole



LA10C

Versione: Cieca
Finitura: Lino caki
Telaio: Standard mostre filo luce
Maniglia: Con foro chiave

Version: Shutter door
Finishing: Lino caki
Frame: Standard flush architrave
Handle: With key hole



LA10V

Versione: Vetro
Finitura: Lino caki
Telaio: Standard mostre filo luce
Maniglia: Con foro chiave

Version: Glass
Finishing: Lino caki
Frame: Standard flush architraves
Handle: With key hole



LA11C

Versione: Cieca
Finitura: Rovere moka
Telaio: Standard
Maniglia: Con foro chiave

Version: Shutter door
Finishing: Rovere moka
Frame: Standard
Handle: With key hole



LA26C

Versione: Cieca
Finitura: Rovere provenza con inserti
in vero complanari
Telaio: Standard mostre filo luce
Maniglia: Con foro chiave

Version: Shutter door
Finishing: Rovere provenza with glass inserts
Frame: Standard flush architraves
Handle: With key hole



LA26V

Versione: Cieca
Finitura: Rovere city con vetro incassato
Telaio: Standard mostre filo luce
Maniglia: Con foro chiave

Version: Shutter door
Finishing: Rovere city with glass inserts
Frame: Standard mostre filo luce
Handle: With key hole



finiture, telai e aperture speciali

**Sistema
Piega**
aperture speciali



**Sistema
Scigno**
aperture speciali



Tutte le porte possono essere realizzate con il sistema di apertura speciale SCRIGNO.

**Techno
Slide**
aperture speciali

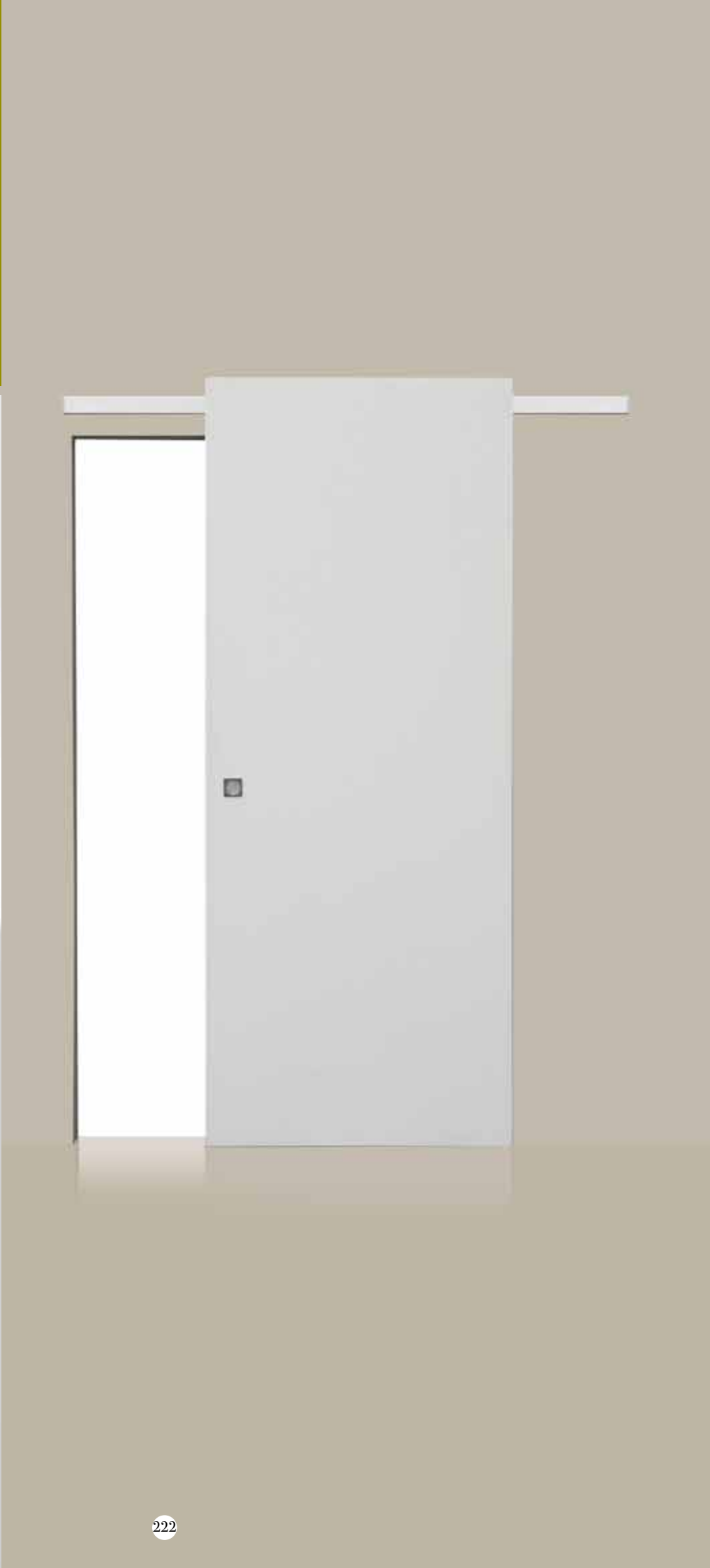

**Scorrevole
esterno
muro**
aperture speciali



Nova Libra

aperture speciali



Sistema Rotea

aperture speciali



*Non disponibile per: mod. GAIA, BELVEDERE, AURORA, ORIZON, STELLA, SIRIO, ORION, VEGA, GHIBLI, RESIDENCE, PRESTIGE, CASTELLO, VILLA, TORRE, CASALE, PALATINA, DOMUS, PORTE CON VETRO.

*Exclusion: mod. GAIA, BELVEDERE, AURORA, ORIZON, STELLA, SIRIO, ORION, VEGA, GHIBLI, RESIDENCE, PRESTIGE, CASTELLO, VILLA, TORRE, CASALE, PALATINA, DOMUS, DOORS WITH GLASS.

Mimetica
aperture speciali

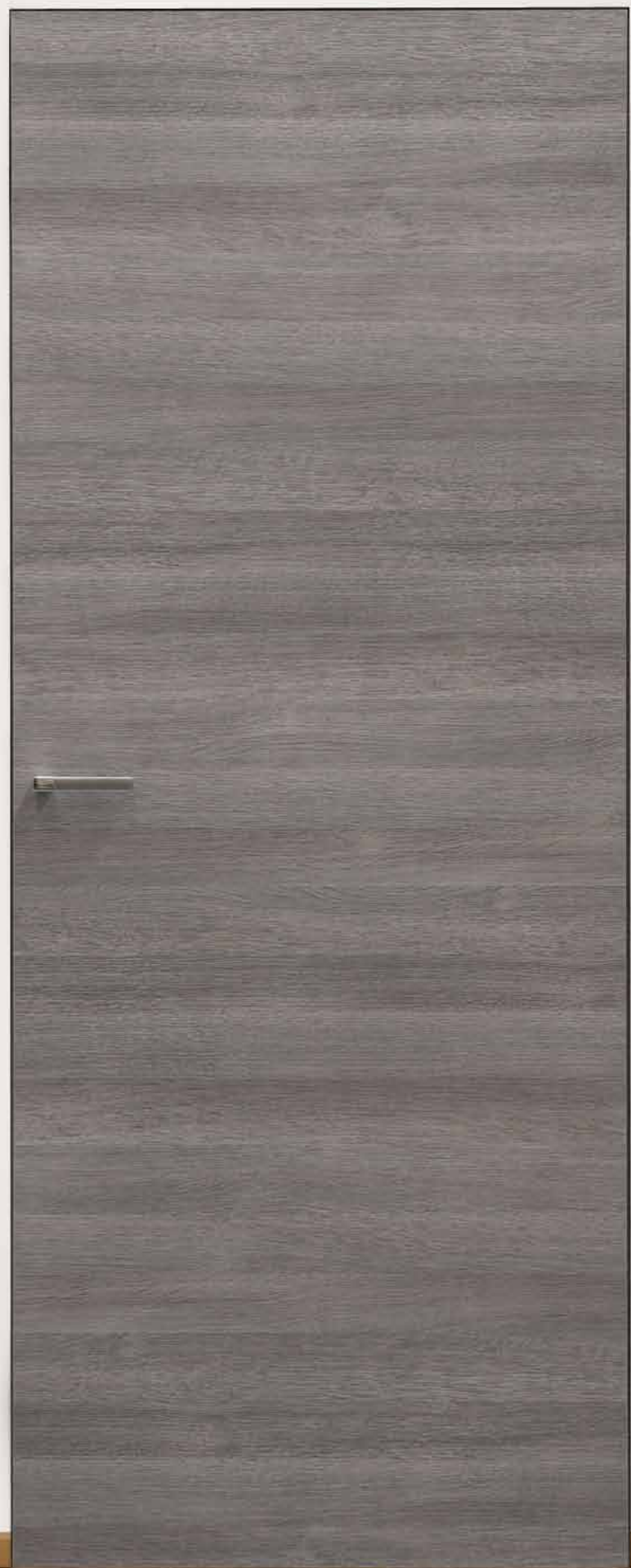

Duan
aperture speciali



Telaio Standard / Frame Standard

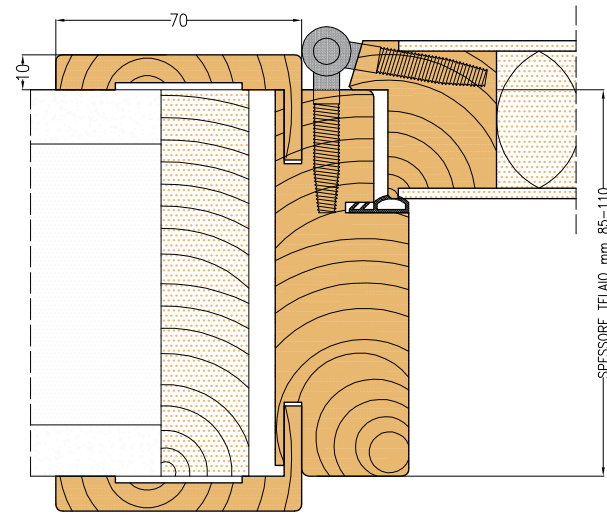

Telaio Ellisse / Frame Ellisse

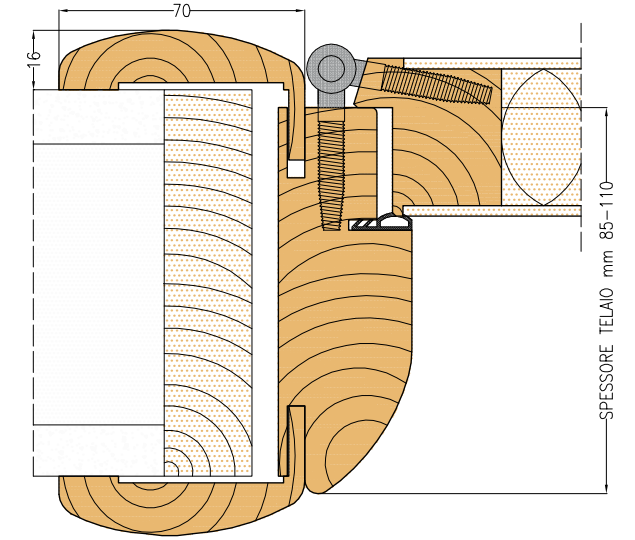

Telaio Design / Frame Design

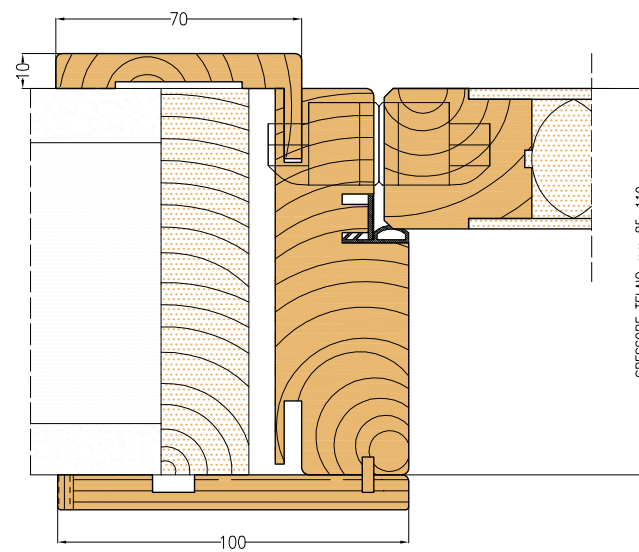

Telaio Eterea Line / Frame Eterea Line

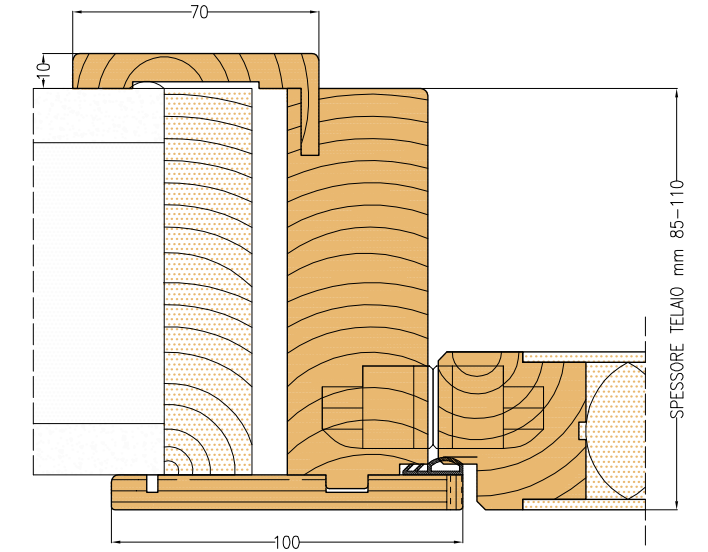

Vetri Satinati Decorati / Decorated Satin Glasses

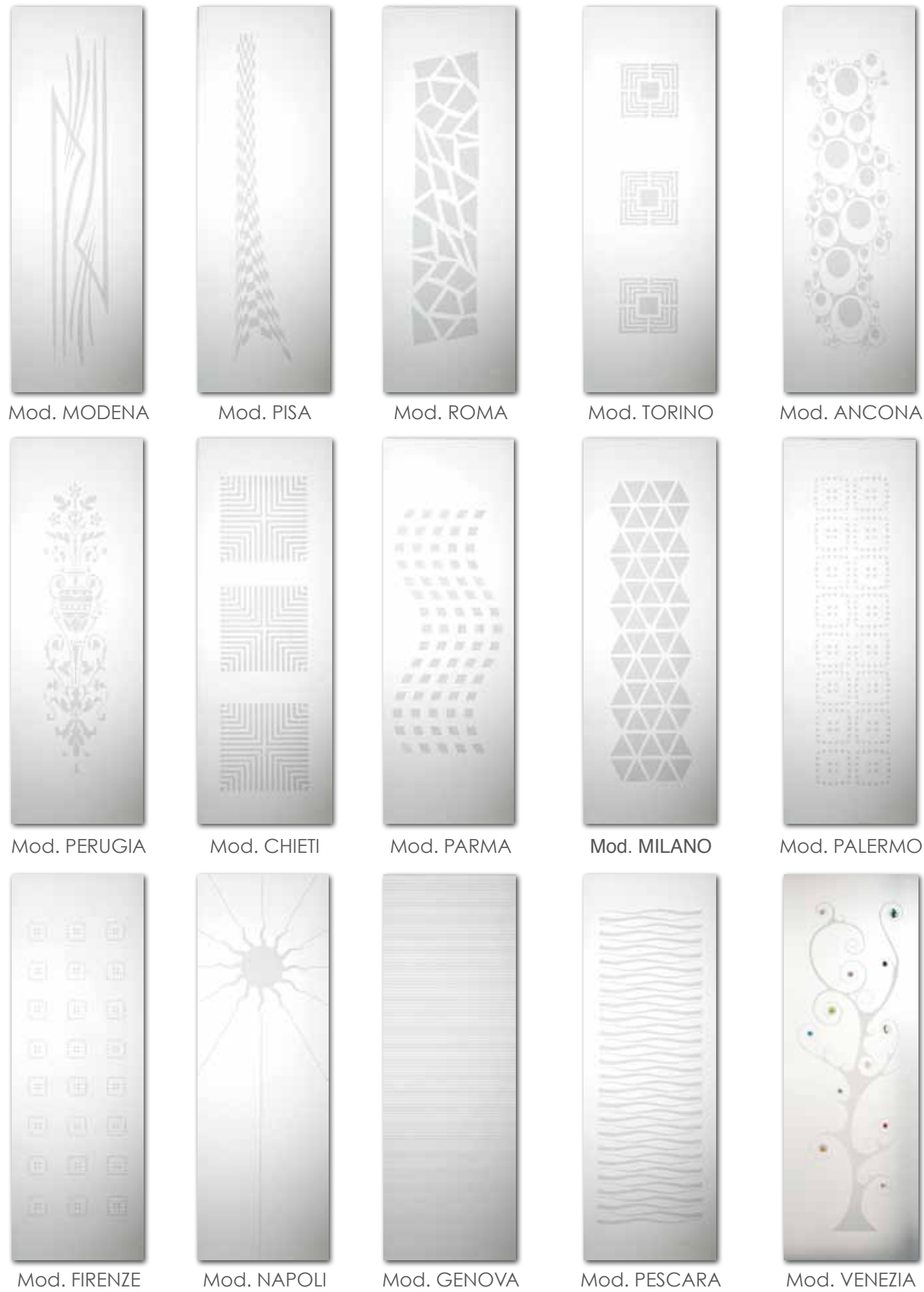

Nota: I vetri suindicati sono tutti "vetri di sicurezza" (temperati o stratificati). / Note: The glasses indicated are all "safety glasses" (tempered or stratified safety glasses).

Vetri / Glasses

Vetri Satinati Colorati / Colored Satin Glasses



Vetri Laccati Lucidi (2 lati) / Polished Lacquered Glasses (2 faces)

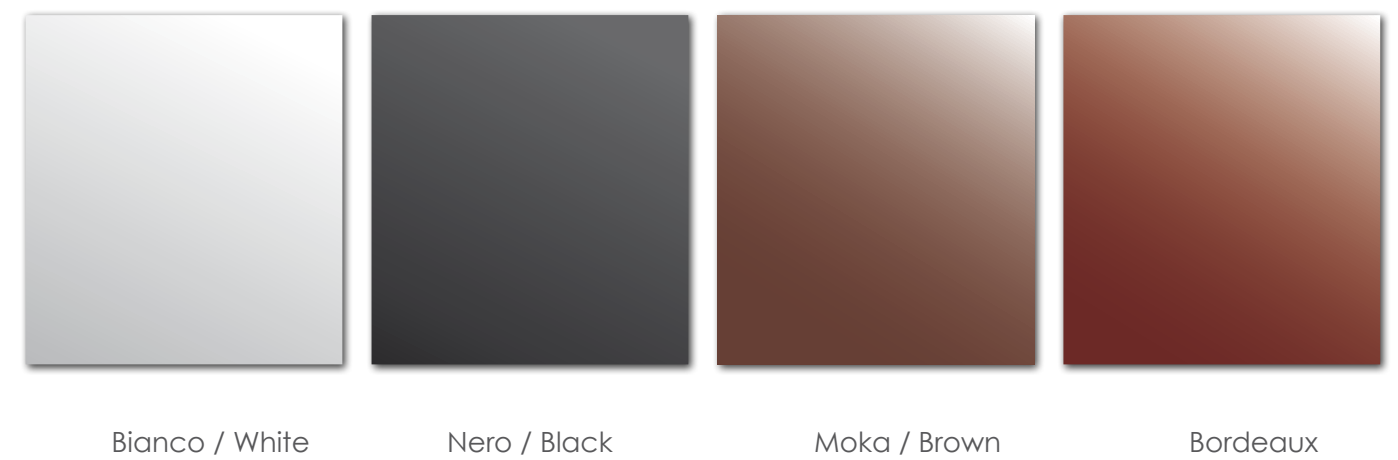

L'azienda si riserva il diritto di apportare modifiche e/o integrazioni a prodotti, decorazioni e accessori in qualsiasi momento e senza preavviso.
The Company reserves the right to make changes and/or implementations in products, decorations and accessories at any moment and with no previous notice.
Nota: I vetri suindicati sono tutti "vetri di sicurezza" (temperati o stratificati). / Note: The glasses indicated are all "safety glasses" (tempered or stratified safety glasses).

Decorati



decorato bianco
decorato white



decorato crema
decorato cream

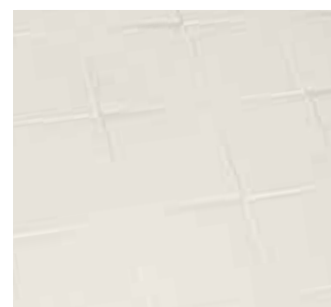

decorato bianco scacchi
decorato white chess



decorato bianco shanghai
decorato white shanghai

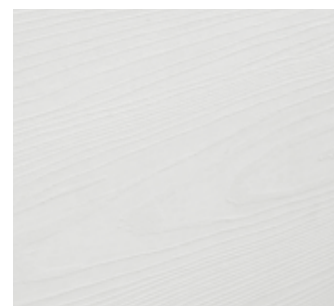

decorato bianco brushed
decorato white brushed



decorato bianco frassino
decorato white ash



decorato rovere provenza
decorato oak provence

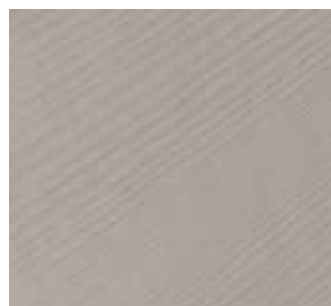

decorato lino delavè
decorato Delavè linen



decorato lino kaki
decorato khaki linen

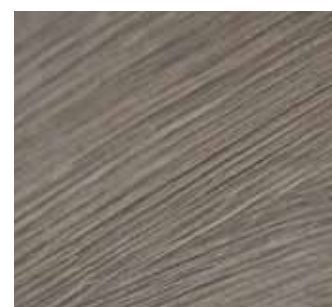

decorato rovere city
decorato oak city



decorato rovere naturale
decorato natural oak



decorato rovere mocaccino
decorato mocaccino



decorato rovere moka
decorato moka oak



decorato rovere sbiancato
decorato white oak



decorato wengé
decorato wengé



decorato ciliegio
decorato cherry



decorato noce biondo
decorato medium walnut



decorato noce nazionale
decorato italian walnut

Essenze

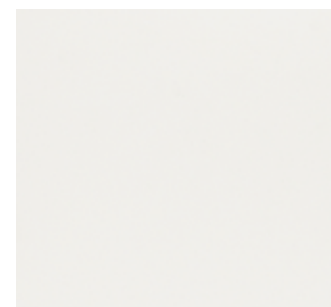

laccato bianco
white lacquered



laccato RAL 9001
RAL 9001 lacquered



laccato bianco spazzolato
brushed white lacquered



rovere bianco cera
white tinted oak



rovere tortora cera
tortora tinted oak



rovere f. castagno cera
chestnut tinted oak



rovere tabacco cera
tobacco tinted oak



rovere fumé cera
fumè tinted oak

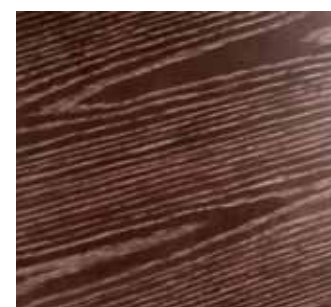

rovere moro cera
moro tinted oak



rovere
oak

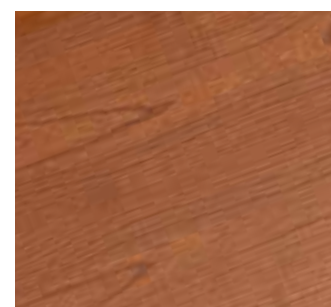

ciliegio
cherry

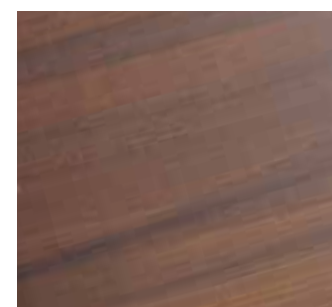

noce nazionale
italian walnut

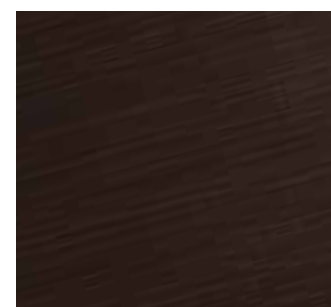

wengé
wengé



multirovere
multioak

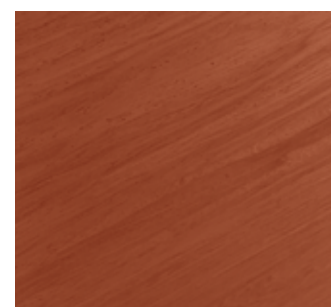

multiciliegio
multicherry

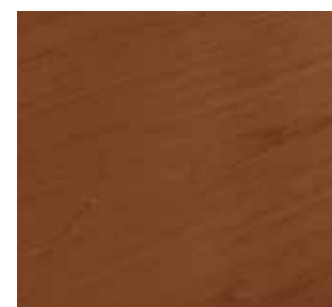

multinoce
multiwalnut

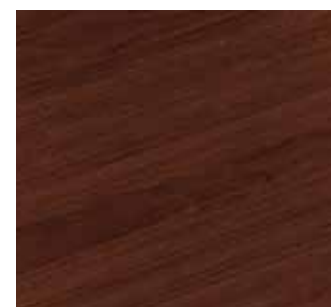

multicanaletto
multicanaletto

Maniglie / Handles



Mod. BASICA
Bronzo / Bronze



Mod. BASICA
Argento / Silver



Mod. SICURA
Resina Nera / Black

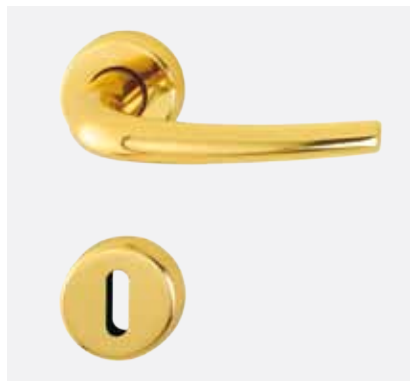

Mod. SINUOSA
Ottone Lucido / Polished Brass



Mod. SINUOSA
Cromo Satinato / Satin Chrome



Mod. SINUOSA
Cromo Lucido / Polished Chrome



Mod. QUADRA
Ottone Lucido / Polished Brass



Mod. QUADRA
Cromo Satinato / Satin Chrome



Mod. QUADRA
Cromo Lucido / Polished Chrome

L'azienda si riserva il diritto di apportare modifiche e/o integrazioni a prodotti, decorazioni e accessori in qualsiasi momento e senza preavviso.
The Company reserves the right to make changes and/or implementations in products, decorations and accessories at any moment and with no previous notice.

